

HEAT-TIMER

INSTALLATION/OPERATING INSTRUCTIONS

TEMPERING VALVE

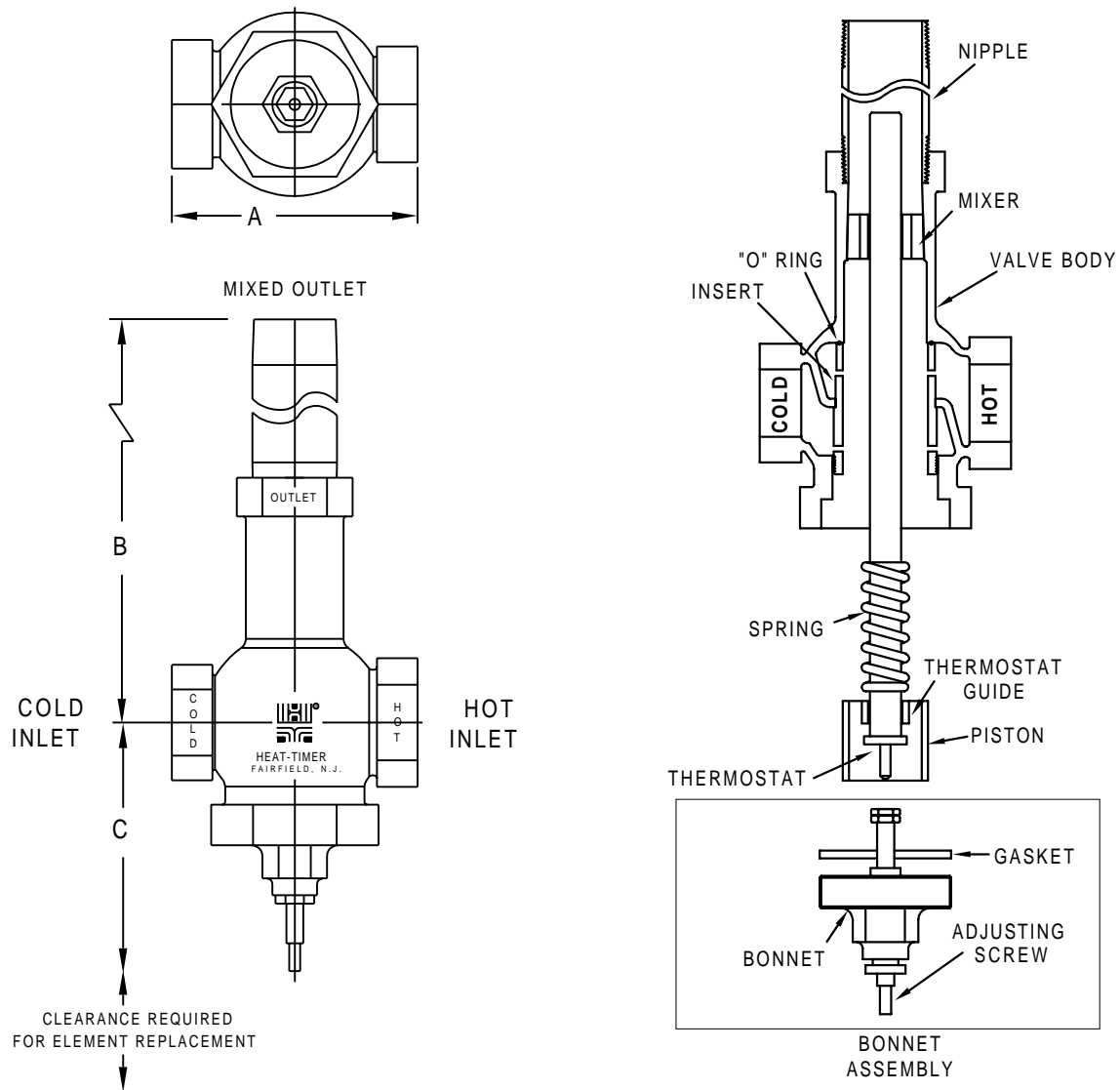

VALVE SIZE	A	B	C	CLEARANCE FOR ELEMENT REPLACEMENT	STANDARD PIPE TAP			PRESSURE DROP CHART \ PRESSURE LOSS					
					MIXED OUTLET	HOT INLET	COLD INLET	1 P.S.I.	2 P.S.I.	5 P.S.I.	10 P.S.I.	15 P.S.I.	20 P.S.I.
1/2"	4 1/2"	8"	4 1/2"	7"	1/2"	1/2"	1/2"	4	6	9	14	17	19
3/4"	4 1/2"	8"	4 1/2"	7"	3/4"	3/4"	3/4"	5	7	12	16	19	22
1"	4 1/2"	11 1/4"	4 1/2"	12"	1"	1"	1"	7	9	15	20	24	29
1 1/4"	4 3/4"	19"	5"	19"	1 1/4"	1 1/4"	1"	12	17	27	38	44	52
1 1/2"	5 1/2"	23"	5"	24"	1 1/2"	1 1/2"	1 1/4"	14	19	29	41	48	57
2"	6 3/8"	25"	6"	24"	2"	2"	1 1/2"	20	31	65	91	110	130
2 1/2"	7 1/2"	27 3/4"	6"	28"	2 1/2"	2 1/2"	2"	51	70	115	170	190	226
3"	9"	29 1/8"	6 1/2"	28"	3"	3"	2 1/2"	59	78	131	183	209	251
4"	10 1/4"	31"	7"	28"	4"	4"	4"	92	135	217	296	373	405

GALLONS PER MINUTE

INSTALLING THE TEMPERING VALVE

FIRST read and examine all the instructions and piping diagrams in this section and the CORRECT/INCORRECT examples on pages 4, 5, and 6. The tempering valve **MUST** be installed as described below. If you have any questions, contact us at our Fairfield, New Jersey facility (973)-575-4004.

VALVE ORIENTATION

- The valve can be installed in any position. It is not necessary to pipe the valve so it is vertical or horizontal.
- Choose a location with at least 28" of clearance in front of the adjusting screw (#6 on the diagram below). This will allow access to internal components in the future.

CONNECT THE HOT PORT

- The HOT inlet port is clearly marked "HOT" on the valve body.
- Connect the hot water supply source to the HOT port as shown at #1 on the diagram below.
- The hot water supply source **MUST** be able to provide water at least 20°F hotter than the desired outlet temperature even under maximum flow conditions.

INSTALL THE THERMAL HEAT LOOP

- The cold water line to the *hot water supply source* **MUST** have a Thermal heat loop as shown at #2 on the diagram below (see pages 4 and 5 for explanation).
- The Thermal heat loop can be installed either up or down, but must be a minimum of 32 inches as measured from center to center.
- The Thermal heat loop prevents the higher temperature water in the hot water supply source from backing up and entering the cold water inlet side of the Heat-Timer tempering valve. As this heat transfer will occur when there is little or no flow in the system, check valves or spring checks can **NOT** be used (see pg. 6).

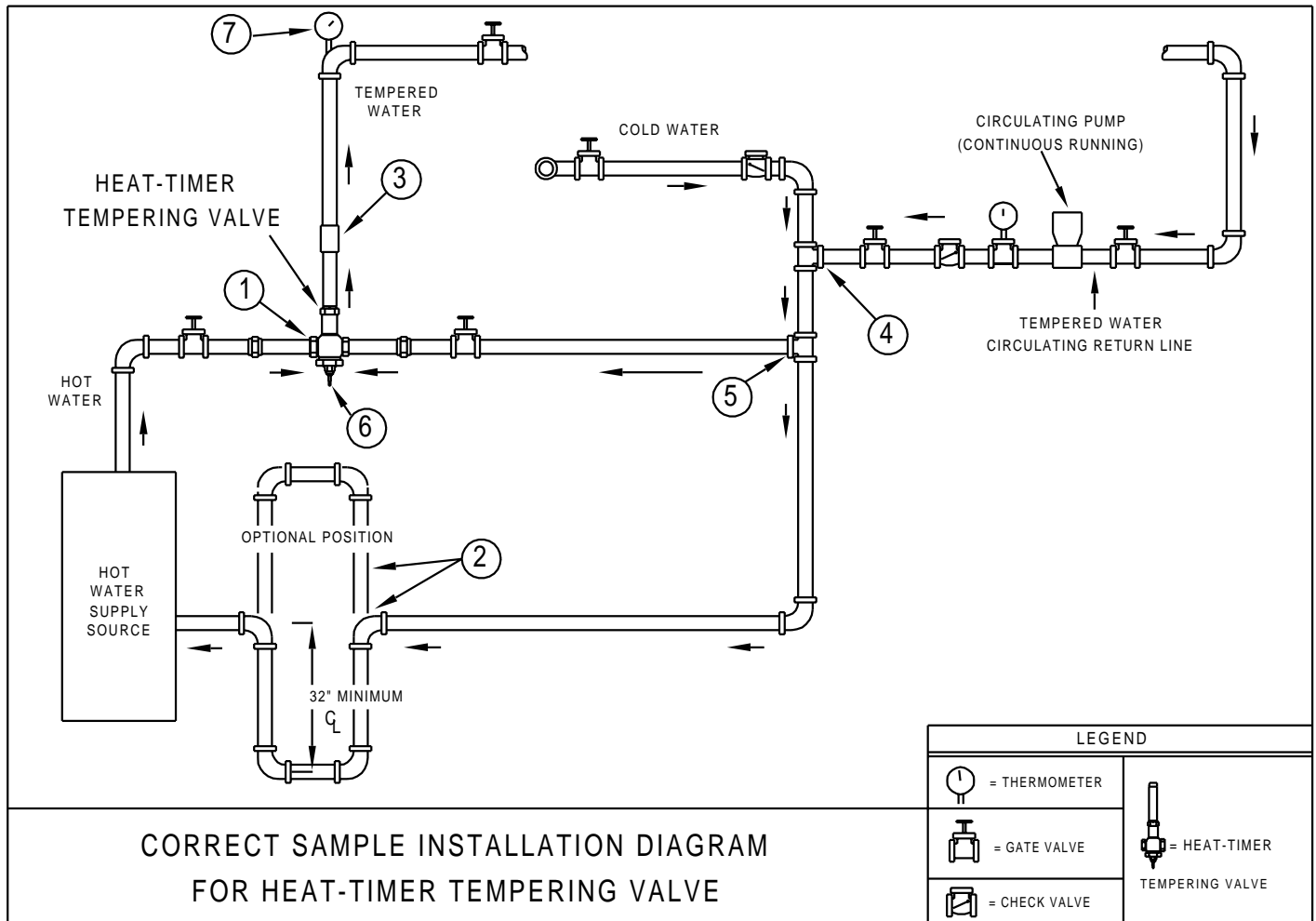

CONNECT THE OUTLET PORT

- The OUTLET port is clearly marked "OUTLET" on the valve body.
- The tempered water supply to the system should be taken from the brass pipe on the OUTLET port as shown at #3 on the diagram (opposite page).
- To adjust the valve properly, install a thermometer (#7 on diagram opposite page) in the tempered water line a minimum of 6 to 10 feet downstream from the outlet end of the tempering valve and before any tempered water supply feeds.

CONNECT THE TEMPERED WATER RETURN LINE

- The tempered water return line must be connected so it will return to the cold water supply of **BOTH** the hot water supply source **AND ALSO** the cold water inlet side of the tempering valve as shown at #4 of the opposite page diagram. (For an explanation of this piping arrangement, see page 4).
- A circulating pump **MUST** be installed on this return line, and **MUST** run continuously.
- The temperature of the tempered water circulating return line should be at least 7° less than the outlet temperature of the valve. If the return line does not drop the 7°, the water temperature at the outlet will begin to rise.
- It is beneficial to install a thermometer in the return line as close to the connection of the main cold water line as possible.

CONNECT THE COLD PORT

- The cold water line to the valve must be taken from the main cold water supply line **AFTER** the tempered water return line as shown at #5 on the opposite page diagram. This is due to the fact that when there is no flow, no cold water can enter the system. By bringing the cooler return water into the cold port, the valve can maintain the correct water temperature (see pg. 4).

WARNING

The Heat-Timer tempering valve is a primary tempering valve and is NOT designed or recommended to be used as a "Failsafe" or "Anti-Scald" valve. For safety, it may be required to install separate anti-scald and safety devices.

ADJUSTING THE TEMPERING VALVE

First check that the valve has been installed in the manner described in the previous section. Then, carefully follow these steps to correctly adjust the outlet water temperature:

1. Turn adjusting screw (#6 on diagram opposite page) into the valve body (clockwise) until only approximately 3/4" of the screw extends from the end of the bonnet.
2. If possible, open the control valve on the cold water supply line to the tempering valve.
3. Next, open the control valve on the outlet end of the tempering valve.
4. Open a few faucets on the tempered water line and keep them running while adjusting the valve.
5. Now, open the control valve from the hot water supply source to the tempering valve.
6. Note the temperature of the tempered water circulating return line. It must be at least 7°F cooler than the desired outlet temperature. If not, turn off the return pump, and allow the system to cool to this point.
7. Turn the adjusting screw out (counterclockwise) the recommended number of turns (chart below). Each turn will change the outlet water temperature approximately 7°.
8. Wait two minutes after turning the screw before reading the temperature of the outlet tempered water.
9. Repeat steps 7 and 8 until the desired outlet temperature is attained.

Valve Size	Adjusting Screw Turns
1/2"	1/2 Turn at a time
3/4"	1/2 Turn at a time
1"	1/2 Turn at a time
1 - 1/4"	1 Turn at a time
1 - 1/2"	2 Turns at a time
2"	2 Turns at a time
2 - 1/2"	3 Turns at a time
3"	3 Turns at a time
4"	3 Turns at a time

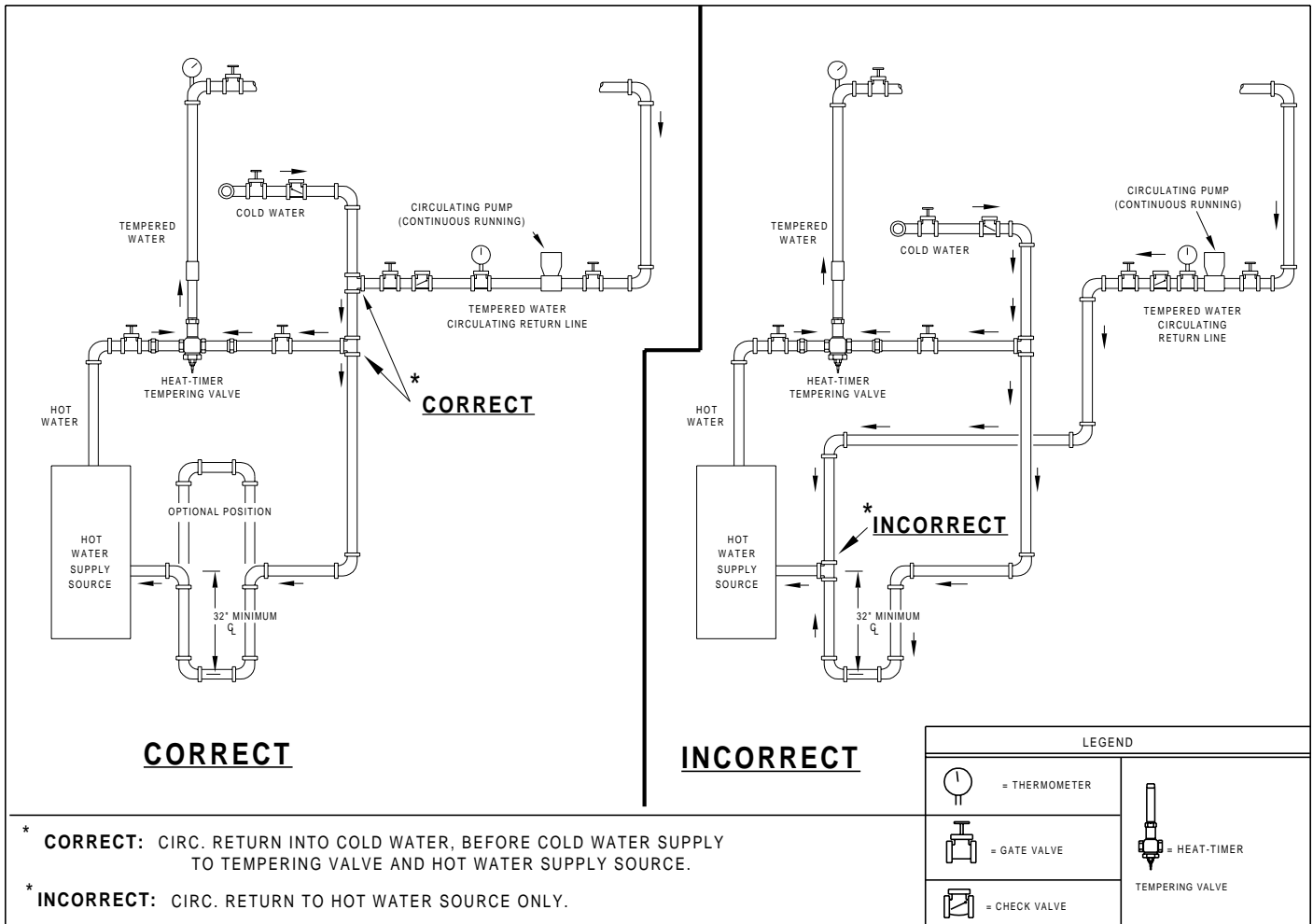

PROBLEM:

When the circulating return line is piped only into the hot water supply source (as in the **INCORRECT** diagram above), the temperature of the system water will tend to be much hotter than the desired water temperature during periods of low or no flow. The system water temperature will return to normal once flow is reestablished. However, after repeated incidents, the thermostat may be damaged.

The tempering valve requires that the temperature of the water at the cold port be at least 7° less than the desired outlet water temperature. This is due to the fact that the tempering valve's function is to mix hot water with cold water to provide a constant outlet temperature.

The **INCORRECT** piping diagram will not allow there to be any cold water available at the cold inlet port when there is little or no flow. When there is no flow, none of the fixtures in the system are using water. Since the pipes can not expand to take more water into the system, this means that none of the cold water from the street can enter the system. Therefore, the system water will pass out of the outlet of the valve, travel around the piping, and then return into the hot water supply source. Each time the water passes through the hot water supply source, it will get hotter and hotter. As no cold water can be mixed in, the temperature of the outlet will begin to rise.

SOLUTION:

By piping the circulating return line into the cold water line before the cold water supply, this situation is avoided. The cold port of the valve will see the water temperature of the circulating return line. As the system water travels through the pipes, even with no flow out, it will lose some of its temperature to the piping and the building. In most cases, the water temperature will drop at least the required 7°. The valve will then be able to mix the hot water supply temperature with the cooler return temperature to make the desired outlet temperature.

NOTE: If the desired outlet temperature is 120°F, this means the temperature of the water at the cold port can be as high as 113°F. 113°F is not normally considered to be cold. However, to the valve trying to make 120°F, it will be cold enough to mix in some of the hot water supply temperature.

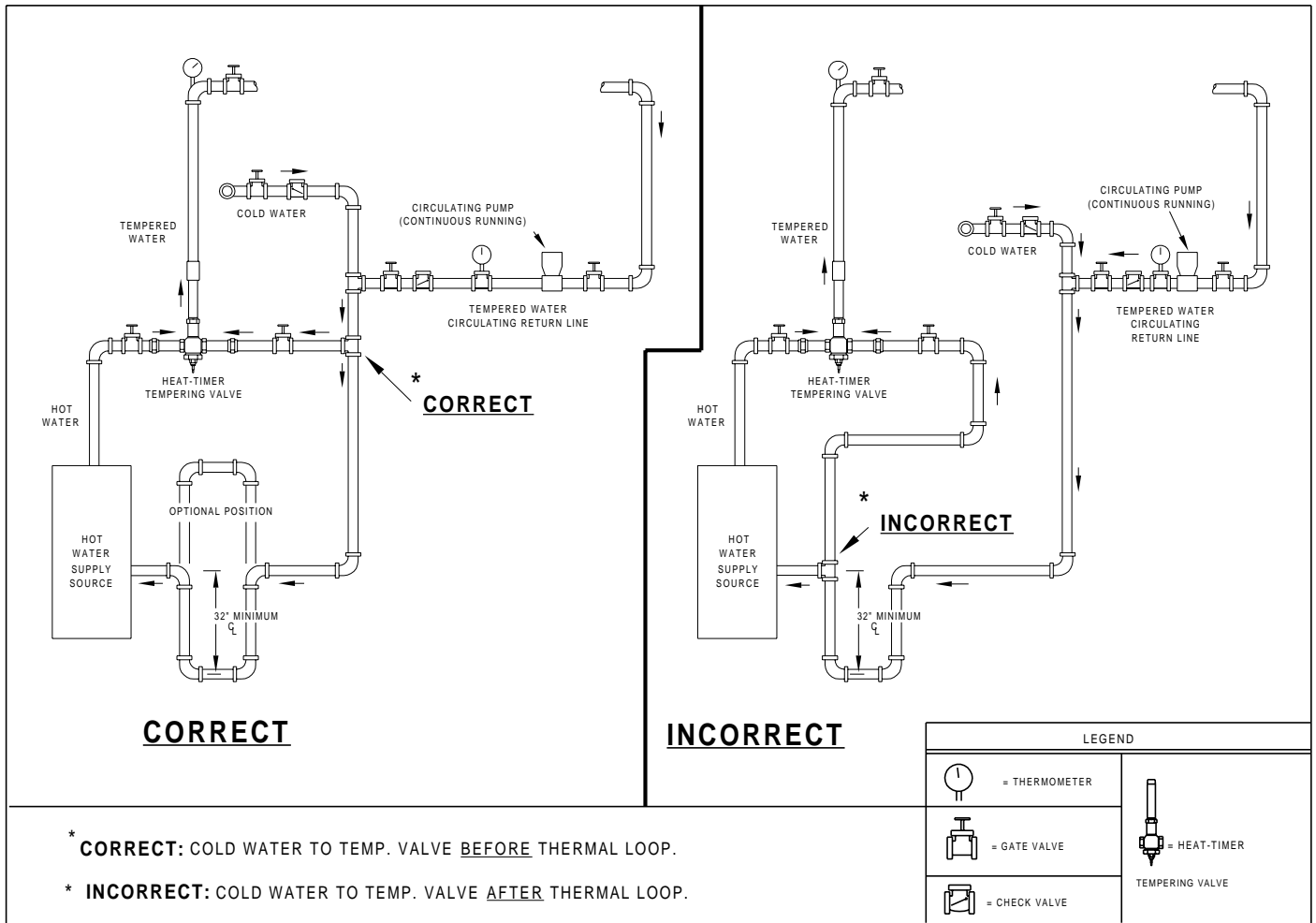

PROBLEM:

When the cold water is piped into the tempering valve after the thermal loop (as in the INCORRECT diagram above), the temperature of the system water will tend to be much hotter than the desired water temperature during periods of low or no flow. The system water temperature will return to normal once flow is reestablished. However, after repeated incidents, the thermostat may be damaged.

The tempering valve requires that the temperature of the water at the cold port be at least 7° less than the desired outlet water temperature. If the temperature of the water at the cold port rises to within 7°, or even rises above the desired outlet water temperature, the valve will have no cold water to mix in with the hot water. In fact, when both the hot and the cold port have water temperatures above the desired outlet temperature, the outlet temperature must rise. In other words, the outlet temperature of the valve can not be lower than the input temperatures.

The INCORRECT piping arrangement will cause the temperature of the water at the cold port to rise when there is little or no flow. When no cold street water can be introduced into the system (because no water is being taken out of the fixtures), the heat from the hot water supply source will radiate up into the cold port of the valve. Eventually, the temperature of the cold port will increase to the point where the desired outlet temperature will begin to rise. Once this occurs, the system water will keep getting hotter and hotter until a fixture is opened and cold street water is reintroduced.

SOLUTION:

By piping the cold water to the tempering valve before the thermal loop, this situation is avoided. The heat from the hot water supply source can not radiate through the 32" minimum pipe loop. The water temperature at the cold port of the valve will therefore remain at the same temperature as the circulating return line during low flow conditions. (see SOLUTION on previous page).

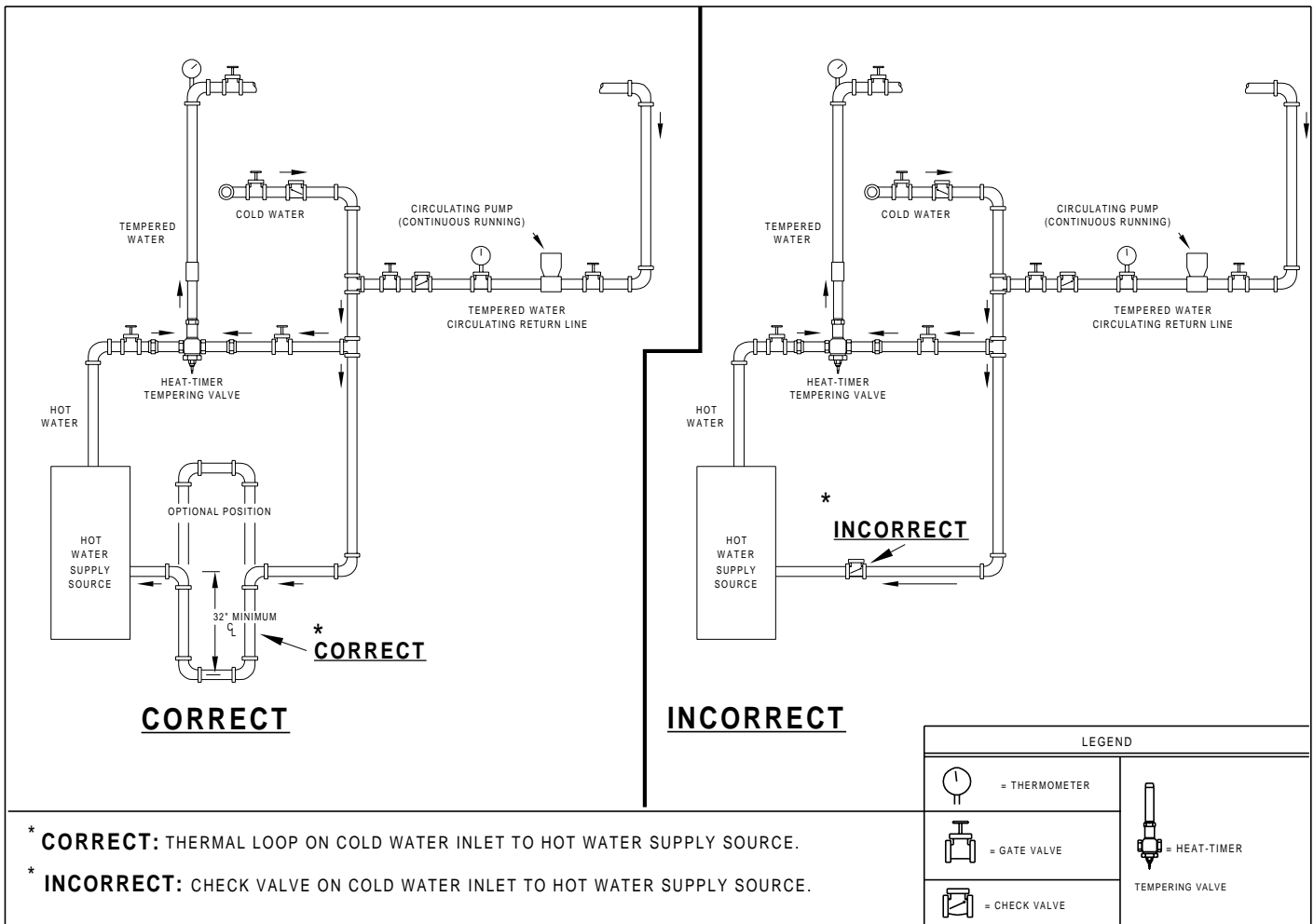

PROBLEM:

As discussed on the previous page, when there is no flow, the heat from the hot water supply source can radiate up into the cold port of the valve. Once this occurs, the outlet water temperature will get hotter and hotter. The **INCORRECT** piping arrangement uses a check valve to prevent this flow of heat into the cold port of the valve.

However, a check valve will not prevent the temperature of the cold port from rising when there is no flow out of the system fixtures. In fact, the check valve will have no effect because there is no flow. A check valve is designed to prevent the flow of water in a certain direction. A check valve would stop hot water from flowing backwards from the hot water supply source into the cold port of the valve. But, the check valve can not prevent the heat from the hot water supply source from radiating back through the piping into the cold port of the valve.

Since the check valve can not stop the heat from radiating, the temperature of the cold port will rise during no flow conditions until it reaches within 7° of the desired outlet temperature. Then the outlet temperature will begin to rise.

SOLUTION:

By piping the cold water to the tempering valve through the thermal loop, the heat from the hot water supply source can not radiate into the cold port (see **SOLUTION** on previous page).

REPLACING THE THERMOSTAT

Select the correct replacement thermostat for your valve by referring to the chart:

Valve Size	Thermostat Length	Heat-Timer Catalog#
1/2"	7 - 1/4"	910000-00
3/4"	7 - 1/4"	910000-00
1"	11"	910001-00
1 - 1/4"	18"	910002-00
1 - 1/2"	23"	910003-00
2"	23"	910003-00
2 - 1/2"	27"	910004-00
3"	27"	910004-00
4"	27"	910004-00

Then carefully follow the instructions to install the new thermostat:

1. Turn off all water to and from the tempering valve.
2. Place a bucket under the bonnet to catch any water and to prevent internal valve parts from falling on the floor.
3. Use a hex wrench to unscrew the bonnet assembly from the valve body. **Be extremely careful to avoid any hot water which may remain in the valve and which could cause severe burns.**
4. Remove the thermostat, piston, and spring from the valve body.
5. Check if the piston can slide freely inside the valve body. If it does not, then remove the piston and polish it with an emery cloth. **DO NOT** polish the inside of the valve body.
6. Assemble the thermostat, piston, and spring outside the valve body. Slide the piston down the thermostat body so that the thermostat guide end of the piston is positioned as shown. Then slide the spring down the thermostat so it rests on the piston.
7. Put the bonnet gasket onto the bonnet as shown.
8. Slide the thermostat, piston, and spring into the valve body. Make sure the end of the thermostat slides into the hole in the mixer (located in the valve body).
9. Screw the bonnet assembly into the valve body. Make sure the adjusting screw rests on the rod protruding from the thermostat.
10. Note the temperature of the tempered water circulating return line. It must be at least 7°F cooler than the desired outlet temperature. If not, turn off the return pump, and allow the system to cool to this point (this may take several hours).
11. Follow the instructions on page 3 to adjust the valve to the desired temperature.

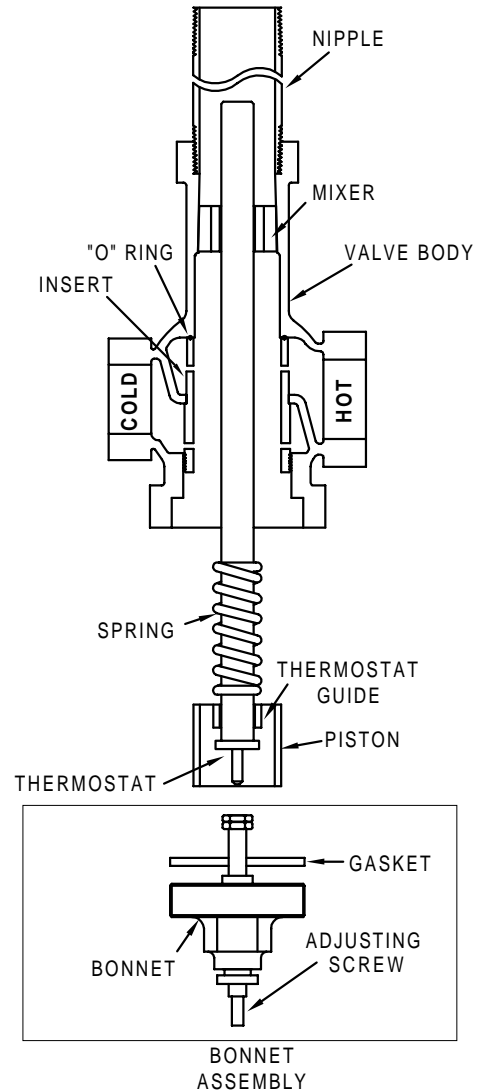

TROUBLESHOOTING

If the outlet water temperature is always too hot and can not be adjusted: Check that the water temperature at the cold port of the valve is below the desired outlet temperature. The valve can not produce outlet water temperatures below the temperature of the cold port. If this is the case, see the condition *If the outlet water temperature is too hot after periods of no or low flow* (below). The water temperature at the cold port must be at least 7° below the desired outlet temperature. If it is not, check if there are any valves or other flow restrictions to the cold port. If the cold water line into the tempering valve does not have any flow restrictions, check the condition *If the piston does not move freely in the valve body* (below). If the piston can move freely, the thermostat may have failed. Call the factory for additional support.

If the outlet water temperature is too hot after periods of no or low flow: Check if the cold water line to the hot water supply source has the thermal heat loop (pg. 2). If the heat trap is installed correctly, check if the circulating pump is running continuously (pg. 3) and that the tempered water circulating return line is at least 7° less than the desired outlet temperature during the low or no flow period. Finally, make sure the tempered water return line is properly connected to the cold water inlet of the valve and the hot water supply source (pg. 3).

If the outlet water temperature is always cold and can not be adjusted: The piston may be installed upside-down. Unscrew the bonnet from the valve body as described in *Replacing the Thermostat* (pg. 7). The thermostat guide portion of the piston must be positioned as shown.

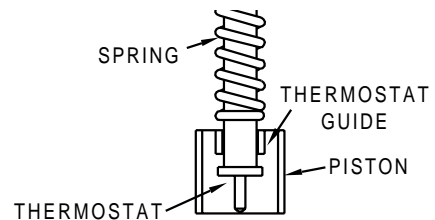

If the outlet water temperature is not hot enough and can not be adjusted: Check the temperature of the water at the hot port of the valve. The hot water supply source must provide the valve with water 20° hotter than the desired outlet water temperature. If the temperature at the hot port is not sufficient, check the hot water line for any blockage or flow restrictions. Also check that the hot water source is activated and is working properly. If it is, see the last condition.

If the outlet water temperature is not hot enough during high flow conditions: Check the hot water supply source. The hot water supply source must be able to provide the valve with water 20° hotter than the desired outlet temperature at all times. If the hot water supply source can not provide sufficient hot water in maximum flow conditions, the outlet water temperature will begin to drop. If the source of hot water is sufficient, check if there are any flow restrictions between the hot water supply source and the hot port of the valve. Finally, check the next condition.

If the piston does not move freely in the valve body: Take out the thermostat, spring, and piston as described in *Replacing the Thermostat* (pg. 7). Slide the piston into the valve body and make sure it can move freely. If it catches on the valve body, remove the piston and polish it with an emery cloth. DO NOT polish the inside of the valve body.

LIMITED WARRANTY

Heat-Timer Corporation warrants that it will replace, or at its option, repair any products or part thereof which is found defective in material or workmanship within one year from the date of installation.

The foregoing is in lieu of all other warranties, express or implied, and Heat-Timer Corporation specifically disclaims any and all warranties of merchantability or fitness for a particular purpose.

Under no circumstances shall Heat-Timer Corporation, its authorized representatives, affiliated or subsidiary companies be liable for special, consequential or incidental damages. Except as specially stated in these terms and conditions of sale, the sole remedy with respect to any product or part sold or manufactured by Heat-Timer Corporation shall be limited to the right to replacement, or at Heat-Timer Corporations option, repair F.O.B., Fairfield, New Jersey.

For Technical Support or Additional Product Information Contact:

Heat-Timer Corporation
20 New Dutch Lane
Fairfield, NJ 07004

Phone (973)575-4004 Fax (973)575-4052
<http://www.heat-timer.com>

HT #059166
Rev --