

HEAT-TIMER®

INSTALLATION/OPERATING INSTRUCTIONS

PLL (Pump Lead Lag) Installation Manual

PROVIDES PUMP ROTATION, AUXILIARY PUMP ACTIVATION, AND PUMP FAILURE ALARM CONTROL

The PLL control provides a lead-lag rotation functionality to a dual pump system. In addition, it is capable of controlling two operating pumps and one auxiliary pump in a 3 pump system.

In a 2 pump system, the PLL acts as a rotation control to rotate the lead pump either based on alternating demand/per call or timed rotation. Rotation can be field configured via dip switches. Alternating demand, activates a different pump each time a call for pump is initiated. The demand must be initiated through *Pump1 Input terminals*. Timed rotation has four options; 4 hours, 12 hours, 24 hours, and 7 days rotation. When rotation is to take place while the lead pump is in operation, the lag pump relay will energize and the lead pump will continue to run, in addition to the lag pump, for a few extra seconds to prohibit the flow switch from tripping and restarting the boiler.

If the lead pump flow fails for over 30 seconds, using *Flow1 input terminals*, the PLL will de-energize that pump relay, turn on the relevant pump LED alarm, and energize the lag pump relay and the 2 alarm relays. If the lag pump flow fails for over 30 seconds while the lead pump is in alarm, the PLL will de-energize the 2nd pump relay and turn on the relevant pump LED alarm. The PLL will not operate any pumps until the situation has been rectified and the Reset button is pushed.

In a 3 pump system, this configuration is typically used in a Multi-Boiler Feed application, rotation functionality is available. The PLL control manages an auxiliary pump in addition to 2 primary pumps. The auxiliary pump will run whenever any of the primary pumps fails for over 30 seconds. In that case, the PLL will deenergize that pump relay and energize the auxiliary pump relay and the two alarm output relays in addition to the relevant alarm LED and solenoid valve. If the 2nd primary pump flow fails for over 30 seconds while the 1st primary pump is in alarm, the PLL will de-energize the 2nd pump relay and energize the relevant solenoid valve. This will allow the auxiliary pump to replace both primary pumps until the situation is rectified and the Reset button is pushed.

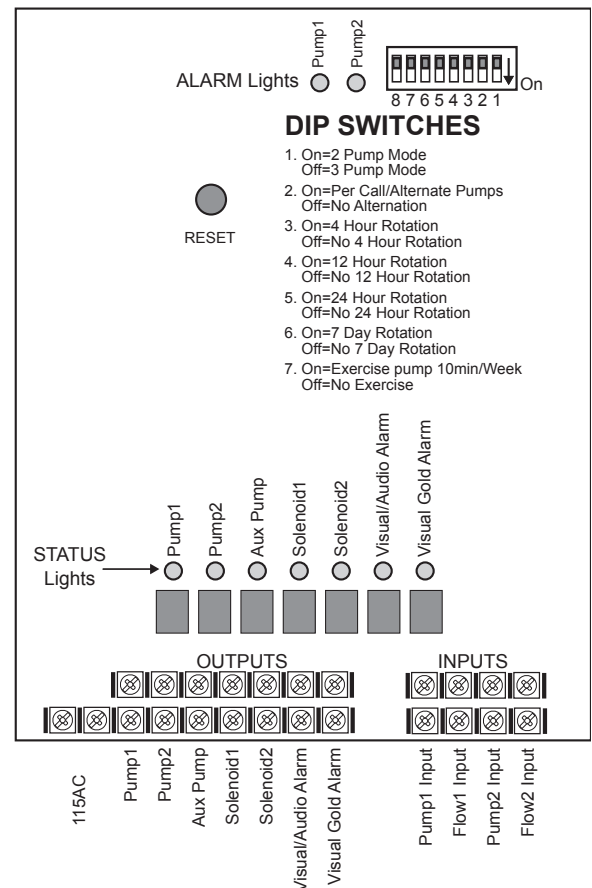

MOUNTING THE ENCLOSURE

- Remove the panel from the enclosure.
- Locate the PLL near the equipment to be controlled but away from excessively high or low temperatures.
- The surface should be flat and sufficiently wide and strong to hold the PLL.
- Screw the enclosure box to the surface through the mounting holes in the back of the enclosure.
- Return the panel to the enclosure and leave the cover open till installation is complete

WIRING POWER INPUTS

- Bring the power wires through the bottom K.O. of the enclosure.
- Attach 120V 60 Hz to the Line and Neutral terminals.
- Class 1 voltage wiring must enter the enclosure through a different opening from any Class 2 voltage wiring. Class 1 copper wire is required by UL.
- Heat-Timer recommends the installation of a Surge Suppressor and a Power Switch before the Power Line connection for safety and ease of service.

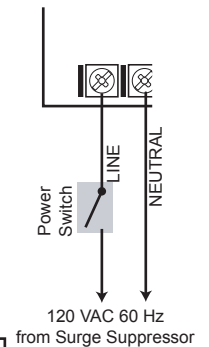

⚠ WARNING

The PLL is an operating control only. It is the responsibility of the installer to verify that all the safety and limits required by code are working properly before and after the PLL is installed.

INPUT WIRING

WIRING THE PUMP INPUTS

- The Pump Input wiring must be dry contacts only. If voltage is placed across the PLL input terminals, the PLL may be damaged.
- Wire each Pump input into the corresponding input terminals of the PLL. A single PLL can accept up to two pump inputs, depending on the configuration requirements.
- If PLL is configured to run two alternating pumps, Dip Switch 1 is ON, connect your pump input to Pump Input 1 only. Pump Input 2 is not used in this configuration.
- If PLL is configured to run two system pumps and one auxiliary pump, Dip Switch 1 is OFF, connect both pump inputs to Pump Inputs 1 and 2 accordingly.

WIRING THE FLOW SWITCH INPUTS

- The Flow Input wiring must be dry contacts only. If voltage is placed across the PLL input terminals, the PLL may be damaged.
- Wire each Flow input into the corresponding input terminals of the PLL. A single PLL can accept up to two Flow inputs, depending on the configuration requirements.
- If PLL is configured to run two alternating pumps, Dip Switch 1 is ON, connect your flow input to Flow Input 1 only. Flow Input 2 is not used in this configuration.
- If PLL is configured to run two system pumps and one auxiliary pump, Dip Switch 1 is OFF, connect both flow inputs to Flow Inputs 1 and 2 accordingly.
- If no flow switch is used, jump the flow input terminals. (Heat-Timer recommends using a flow switch for better system response and operation.)

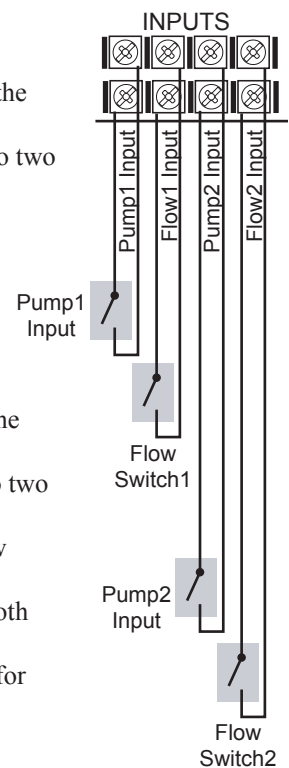

OUTPUT WIRING

WIRING THE PUMP OUTPUTS

- Wire the Pump 1 and Pump 2 terminals to the pumps or pump's starters. Pump 1 and 2 terminals DO NOT supply any power. A separate power source must be provided to power the pumps.
- When in 3 Pump Mode, Dip Switch1 is OFF, wire the Aux Pump terminals to the Auxiliary Pump or pump starter.
- Each set of contacts is capable of switching 1A Inductive, 6A Resistive at 120VAC. Maximum total current allowed on all circuits is 15A.

WIRING THE VISUAL/AUDIO ALARM OUTPUT

- The Visual/Audio Alarm output terminals do not source any power. A separate power source must be supplied.
- Connect the Visual/Audio Alarm relay outputs to an alarm. The Heat-Timer Vis-U-Larm (HT #925011) with both a red light and a buzzer may be used for the alarm.
- Each set of contacts is capable of switching 1A Inductive, 6A Resistive at 120VAC.

WIRING THE VISUAL GOLD ALARM OUTPUT

- Connect the other Alarm output to any Aux Input on a Heat-Timer Platinum panel with a communication package.
- The Visual Gold Alarm output allows a Platinum panel with a communication package to notify the user of an alarm status either through the Visual Gold software, when Platinum panel is purchased with a Visual Gold communication package, or through the internet, when Platinum panel is purchased with the internet communication package.

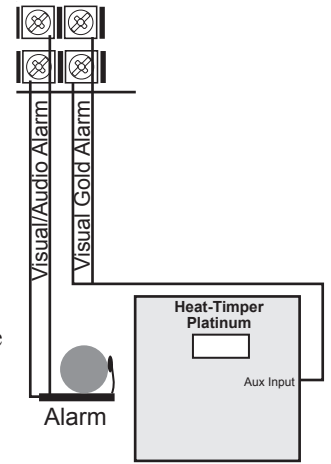

WIRING THE SOLENOID VALVE OUTPUTS

- The Solenoid outputs are only available in 3 Pump Mode, Dip Switch 1 is OFF.
- The Solenoid output terminals do not source any power. A separate power source must be supplied.
- Connect the Solenoid1 Output to the solenoid valve to be activated when Flow1 terminals are open. Connect the Solenoid2 Output to the solenoid valve to be activated when Flow2 terminals are open.
- Each set of contacts is capable of switching 1A Inductive, 6A Resistive at 120VAC.



DIP SWITCHES

SETTING OPERATION MODE (DIP SWITCH 1)

Dip Switch 1 *On = 2 Pump Mode, Off = 3 Pump Mode* Default=On

- The PLL can operate either a 2 rotating pump system or a 2 pump system with an auxiliary pump (3 pump system).
- On a 2 pump system, Dip Switch1 is On, the PLL will rotate the lead pump based on the rotation settings. Pump input signal is wired to Pump1 Input terminals and flow input signal is wired to Flow1 Input terminals. Pump2 Input and Flow2 Input are not used in this mode. PLL Pump outputs must be wired to Pump1 and Pump2. Solenoid output terminals are not used in this mode.
- On a 3 pump system, Dip Switch1 is Off, the PLL will operate 2 primary pumps and one auxiliary pump. Both pump input signals are wired to Pump1 and Pump2 Input terminals. Both flow input signals are wired to Flow1 and Flow2 Input terminals. Solenoid1 and Solenoid2 output terminals are wired to the corresponding solenoids.

DIP SWITCHES

1. On=2 Pump Mode
Off=3 Pump Mode
2. On=Per Call/Alternate Pumps
Off=No Alternation
3. On=4 Hour Rotation
Off=No 4 Hour Rotation
4. On=12 Hour Rotation
Off=No 12 Hour Rotation
5. On=24 Hour Rotation
Off=No 24 Hour Rotation
6. On=7 Day Rotation
Off=No 7 Day Rotation
7. On=Exercise pump 10min/Week
Off=No Exercise

SETTING PUMPS ROTATION SCHEDULE (AVAILABLE IN 2 PUMP MODE ONLY)

Dip Switch 2 *On = Per Call/Alternate Rotation, Off = No Per Call/Alternate Rotation.*

Dip Switch 3 *On = 4 Hour Rotation, Off = No 4 Hour Rotation.*

Dip Switch 4 *On = 12 Hour Rotation, Off = No 12 Hour Rotation.*

Dip Switch 5 *On = 24 Hour Rotation, Off = No 24 Hour Rotation.*

Dip Switch 6 *On = 7 Day Rotation, Off = No 7 Day Rotation.*

- Only in 2 pump system, Dip Switch 1 is ON, the PLL can rotate the lead pump.
- The PLL can rotate the lead pump based on demand or time.
- To select the desired Pump Rotation function, set 2, 3, 4, 5, and 6 Dip Switches as per the diagram.
- When several rotation Dip Switches are set to ON, the higher number Dip Switch takes priority over lower number ones.

SETTING PUMP EXERCISE

Dip Switch 7 *On = Exercise Pump 10 Sec/Week of non-operation, Off = No Pump Exercise* Default=On

- When Dip Switch7 is set to On, the PLL will energize the pump relay for 10 minutes for every week of non-operation.
- This feature is helpful in reducing pump rotor lock due to sediment deposit and rust in the system pipes.
- In vacuum pump applications, it assist in periodic vacuum pump lubrication.

OPERATION

2 PUMP MODE

- By setting Dip Switch 1 to On, The PLL will operate in a 2 Pump Mode. In this mode, the PLL will receive input from a Pump1 Input call and a Flow1 switch closure.
- Pump2 and Flow2 Inputs have no effect on the PLL operation in this mode.
- When Pump1 Input terminals are closed, the PLL will start the lead pump. If flow proved through Flow1 Input terminals, the lead pump will continue operation until either, Pump1 Input terminals are opened or flow input terminated for over 30 seconds.
- When timed rotation is selected and due, the lag pump will initiate while the lead pump is in operation. This operation overlap will continue for a few seconds to guarantee flow continuity during rotation.
- If during the operation of either pump, flow did not prove for over 30 seconds, the lag pump will take over and the respective failing pump alarm LED will blink in addition to the Alarm output relays.
- In the case were flow does not prove on either pump, both pump relays will deenergize and both pump alarm LEDs will blink. After the Reset button has been pushed, normal operation should continue.

2 Rotating Pump System

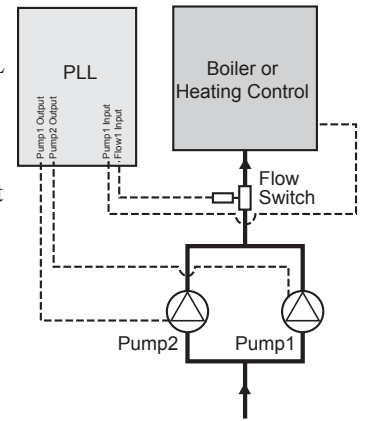

3 PUMP MODE (MULTI-BOILER FEED PUMP APPLICATION)

- By setting Dip Switch 1 to Off, the PLL will operate in a 3 Pump Mode. In this mode the PLL will receive input from both Pump1 and Pump2 Input terminals and flow from both Flow1 and Flow2 inputs. Pump rotation has no effect on PLL operation in this option.
- When either or both Pump Inputs are closed, the PLL will start the respective primary pumps by energizing their relays. If flow proved through the Flow Input terminals, the primary pumps will continue operation until either Pump Input terminals are opened or either Flow Input is terminated for over 30 seconds.
- If during the operation of either pump, flow did not prove for over 30 seconds, the Aux pump will take over and the respective failing pump alarm LED will blink in addition to the Alarm output and respective Solenoid relays.
- In the case were flow does not prove on either of the primary pumps, both pump relays will deenergize and both pump alarm LEDs will blink in addition to the respective Solenoid relay. The Aux Pump will do the work for both pumps and no flow checking will take place. After the Reset button has been pushed, normal operation should continue.
- When the Reset button is pushed while Aux pump is in operation, only the Pump output relay where flow is proved through the respective terminals will energize. Otherwise, the Aux pump will continue operation.

Multi-Boiler Feed Pump Application

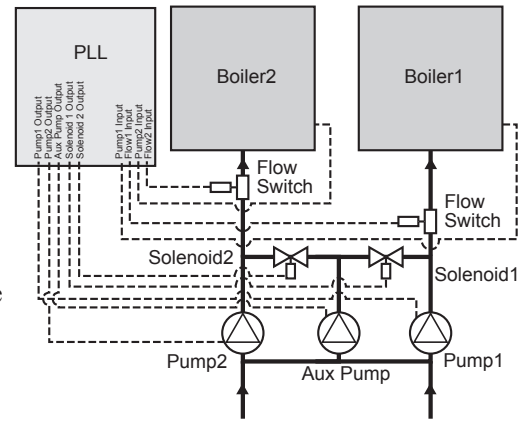

SPECIFICATION

- 2 Rotating Pump Operation mode.
- Multi-Boiler Feed Pump Operation with an Auxiliary Pump. (3 Pump mode.)
- Rotation Options Alternate, 4 Hour, 12 Hour, 24 Hour, and 7 Days. (Available in 2 Pump Mode only.)
- When in timed rotation, Lead Pump will continue to run for a few additional seconds after Lag Pump starts for continual flow.
- Visual Gold Alarm in addition to Visual/Audio Alarm for No flow for 30 seconds.
- Auxiliary Pump operation when any primary pump fails for 30 seconds. (Available in 3 Pump Mode only.)
- Solenoid valve control relays for primary Pump failure. (Available in 3 Pump Mode only.)
- Controllable Pump exercise for 10 seconds for every week of no operation. Applies to all pumps including Auxiliary Pump.
- Input Voltage is 120VAC with maximum power consumption of 12VA.
- All Relays are S.P.S.T. and each is rated for Each set of contacts is capable of switching 1A Inductive, 6A Resistive at 120VAC. Maximum total current allowed on all circuits is 15A.
- Enclosure is a NEMA1 with the following dimension 7 1/8" W x 9 5/8" H x 3 1/2"D.

⚠ WARNING

The PLL Pump Lead Lag control DOES NOT source any power for pumps, alarms or solenoid valves. It operates as a dry contact switch only.

Heat-Timer is aware that each installation is unique. Thus, Heat-Timer is not responsible for any installation related to any electrical or plumbing diagram generated by Heat-Timer. The provided illustrations are to demonstrate Heat-Timer's control operating concept only.