

HEAT-TIMER[®]

INSTALLATION AND OPERATION INSTRUCTIONS

DiGi-SPAN[®] *Elite Series*

RSM DIGI-ELITE Residential Snow Melt Control

Under Slab Snow-Melting Hydronic Heating System

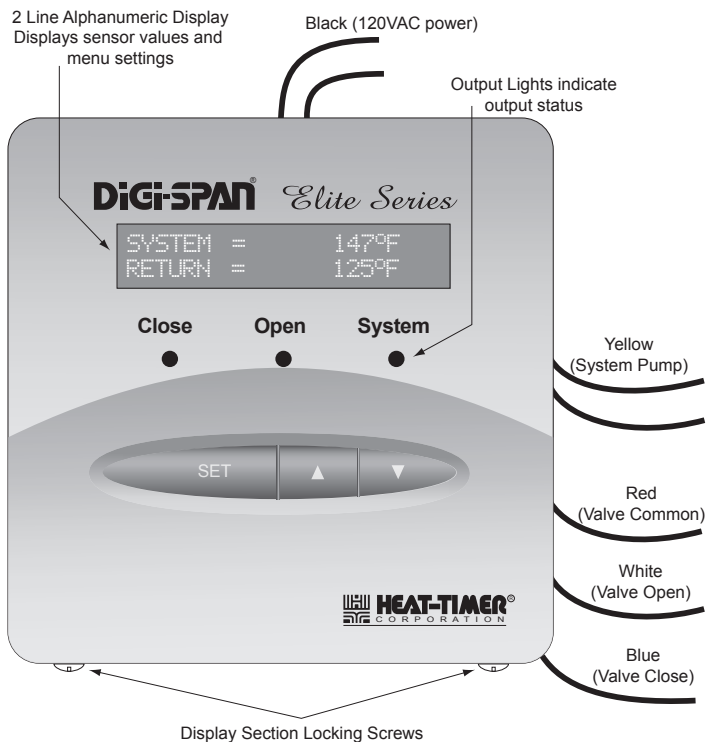

The RSM-Elite is designed to control under slab heating systems to prevent accumulations of ice or snow. To do this, it monitors three temperatures, the outside temperature, the temperature of the fluid going to the slab, and the temperature of the fluid returning from the slab.

The slab must be kept above freezing (32°F) whenever there could be frozen precipitation. Consequently, any ice or snow which falls on the slab will melt immediately. If precipitation is allowed to accumulate before the slab is heated, an effect called bridging can occur. The snow or ice directly in contact with the slab will melt. But, the snow above will act as an insulator, reflecting the heat back into the slab. The slab itself will have no ice touching its surface, but the remaining accumulation will melt very slowly. To prevent this, the RSM-Elite activates the slab heating system whenever the outside temperature falls below the adjustable outdoor cutoff temperature.

Once the slab heating system is activated, the amount of energy entering the slab is determined by the difference between the temperature of the fluid going to the slab (the Slab Supply) and the temperature of the fluid returning from the slab (the Slab Return). The difference between these two is called the Slab ΔT or Delta T. The Slab ΔT will be different for each slab composition based on the slab design. The higher the Slab ΔT , the more energy is being input to the slab. If the Slab ΔT is set larger than its design ΔT , the slab itself may be damaged. The RSM-Elite provides a maximum Slab ΔT adjustment which can be set from 5°F to 50°F. This setting protects the slab during the initial warm-up periods.

After the warm-up period, each slab has a heat loss that varies with the outdoor temperature changes. Thus, a slab might require 130°F fluid temperature at 0°F outdoor temperature to maintain its heat. However, when the outdoor warms to 15°F, it might require only 100°F fluid temperature circulating. The RSM-Elite is provided with a Curve adjustment to insure the slab temperature will be sufficient to melt frozen precipitation once the warm-up period has ended.

⚠ WARNING

This Heat-Timer control is strictly an operating control; it should never be used as a primary limit or safety control. All equipment must have its own certified limit and safety controls required by local codes. The installer must verify proper operation and correct any safety problems prior to the installation of this Heat-Timer control.

The Curve value compensates for both different slab types and different outdoor weather conditions. After making a change in the Curve value, it is necessary to wait at least several hours before accessing what affect it will have on slab temperatures.

The RSM-Elite will control a 3-way motorized mixing valve to regulate the amount of heat being supplied to the slab. The motorized valve will mix the heated fluid from the heat source with the fluid returning from the slab.

Mounting the Controller

- The RSM-Elite is designed to mount on a 1900 (4"x4") deep electrical box.
- If additional room is needed for wiring use the extension skirt provided in the box.
- Place the RSM-Elite in a convenient location near the unit to be controlled.
- Mount the RSM-Elite indoors and away from excessive heat or cold.
- Partially unscrew the Display Cover Mounting screws. This allows for its removal.
- Lifting the Display Section away from the base will unplug it from the Base section.
- Proceed with the power and output wiring instructions.
- Use the screws provided to mount the RSM-Elite to the 1900 box or the extension skirt.
- Mount Display Section back to the Base Section. Tighten the Display Cover Mounting Screws.

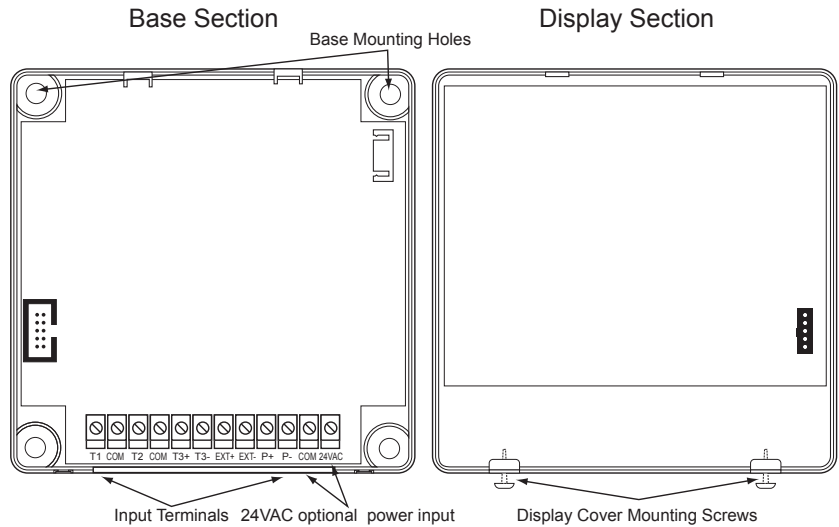

⚠ WARNING

The RSM-Elite can accept only one source of power: 120VAC or 24VAC. If more than one power source is applied, the unit may be damaged.

Wiring

Wiring Power Input

The RSM-Elite is designed to accept **ONLY A SINGLE POWER SOURCE**. It can be wired to either 120VAC using the two Black wires or 24VAC using the right most two terminals on the terminal block on bottom of the control. Heat-Timer recommends the installation of a Surge Suppressor and a Power Switch before the Power Line connection for safety and ease of service.

120VAC

- Attach line voltage, 120VAC, to the two Black wires extending from the back of the RSM. Remember to use the power line from a different source than the equipment being controlled.

24VAC

- Use a dedicated transformer with at least a 5VA output.
- Bring 24VAC to the two right most terminals on the front of the RSM-Elite marked 24VAC and COM.

Wire Colors and Output Lights

- The RSM-Elite has a three S.P.S.T. (single-pole single-throw N.O.) relays. Each output is rated at 1 Amp inductive load or 6A resistive load at 120VAC.
- The RSM-Elite has three lights that follow the output relays operation. When a relay energizes, its LED will turn on.
- The outputs are dry contacts only. They do not source any power.
- The two Yellow wires represent System Output relay and the right LED. The System output can control the Slab supply pump. See System Pump Wiring on page 3.
- The Blue wire represents the Valve Close Output relay and the left LED.
- The White wire represents the Valve Open Output relay and the middle LED.
- The Red wire represents Valve Common. This wire must be connected to the valve power source. See Motorized Valve Wiring on page 3.

System Pump Wiring

- Wire the two Yellow wires to the Slab Pump circuit. The relay should be wired to break the power source hot leg. The relay is rated at a maximum of 1 Amp pilot duty (Maximum of 1/8 HP) or 6 amp resistive load at 120VAC.
- The RSM-Elite System output does not source any power. A separate pump power source is required. The relay makes when energized to switch the power to the pump.

Motorized Valve Wiring

- The valve motor must be of the floating type.
- The Red to Blue (Close relay) and Red to White (Open relay) connections are dry contacts only. They do not source any power.
- The two valve relays are N.O. and each is rated at 1 Amp inductive load or 6A resistive load at 120VAC.
- Connect the Red wire to the power source. The second wire from the power source to the valve common terminal.
- Connect the Blue wire to the valve motor Close terminal.
- Connect the White wire to the valve motor Open terminal.

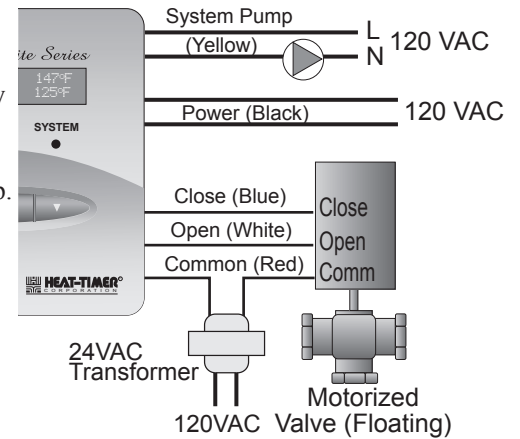

Wiring Input Terminals

Slab Supply and Return Immersion Sensor Installation Supply (T1, COM), Return (T3+, T3-)

- Place the Slab Supply sensor in the header approximately 10' past the mixing valve before any takeoffs where it will register the mixing valve output temperature.
- Place the Slab Return sensor where it will register the slab return temperature before mixing with other returns.
- Only use the Standard Brass Tube sensors included with the control (HT# 904250-00).
- Each of the sensors must be inserted into a 3/8" ID 1/2" NPT immersion well (HT #904011-00).
- The sensor wires can be extended up to 500' using a shielded 2-conductor cable (Belden #8760 or equivalent (#18/2)). Do not connect the shield at the sensor end. But, connect it to the control *COM* and *T3-* terminals. Do not run sensor wires in conduit with line voltage wiring.

Outdoor Sensor Installation (T2, COM)

- Only use the Heat-Timer sensor included with the unit (HT# 904220-00).
- Locate the sensor in the shade on the north side of the building. It should never be in direct sunlight.
- Be sure the location is away from doors, windows, exhaust fans, vents, or other possible heat sources.
- The sensor should be mounted approximately 10' feet above ground level.
- Adhere the Outdoor Label provided to the back of the sensor base.
- Use the Enclosure Base bottom knockout for the conduit. Use the locknut to hold the conduit and enclosure base together. Screw the cover to the base.
- If screws are used to affix the enclosure to the wall, make sure to seal around the sensor and wall except from the bottom.
- The sensor wires can be extended up to 500' using shielded 2-conductor cable (#18/2). Do not connect the shield at the sensor but at the control using the *COM* terminal.
- Do not run sensor wires in conduit with line voltage wiring.

RSM-Elite Input Terminals

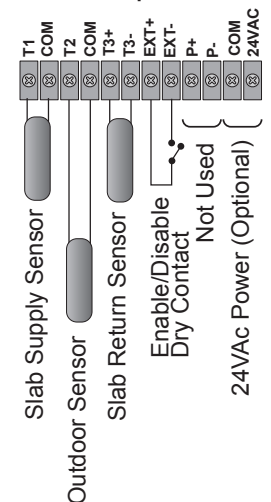

Immersion Slab Sensor

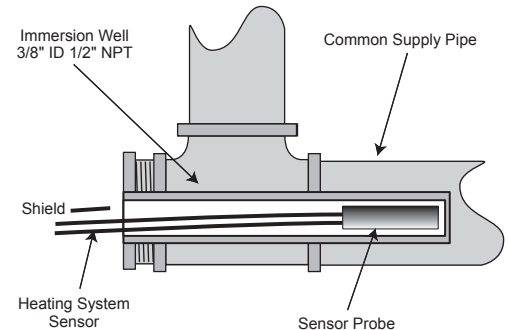

Outdoor Sensor

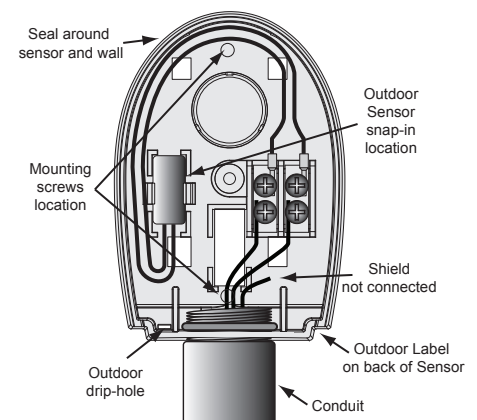

⚠ ALERT

Determining the proper location for the Outdoor Sensor is very important. The RSM-Elite will base its operation on the outdoor temperature information it receives from this location. If the sensor is in the sun, or covered with ice, its reading will be different from the actual Outdoor temperature.

Wiring the Enable/Disable

(EXT+, EXT-)

- The *EXT* \pm terminals can be used to enable or disable the system by connecting it to a switch. It accepts dry contact input only. See Enable/Disable Input on page 8.
- If no thermostat or switch is connected to the *EXT* \pm terminals, leave the jumper supplied as a contact to the terminals.
- The RSM-Elite will not operate the outputs unless the *EXT* \pm terminals are shorted.

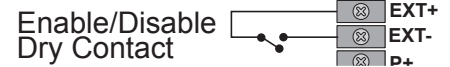

Button and Navigating Menus

The RSM-Elite has three buttons.

- The **SET** button function varies. When the Default Screen is displayed, pressing the **SET** Button views the MENU. When in the menus and settings, the **SET** Button accepts the selected entry or setting value.
- When in the menus, pressing the **Up** and **Down** buttons will scroll through the menu options. They can be used to change the setting of a specific function. i.e., change the Set Point, Differential, or System Trim. In addition, when in the default screen, the **Up** and **Down** buttons will display the outdoor temperature and Outdoor Cutoff when no return sensor is available, or the outdoor temperature and the return temperature when an active return sensor is connected.
- At the end of every operation menu there is a **<Back>** option that allows the user to go back one menu level. If the SET Button was held down for three seconds on the **<Back>** option, the display will go back to the default screen.

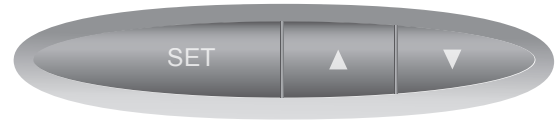

Menus

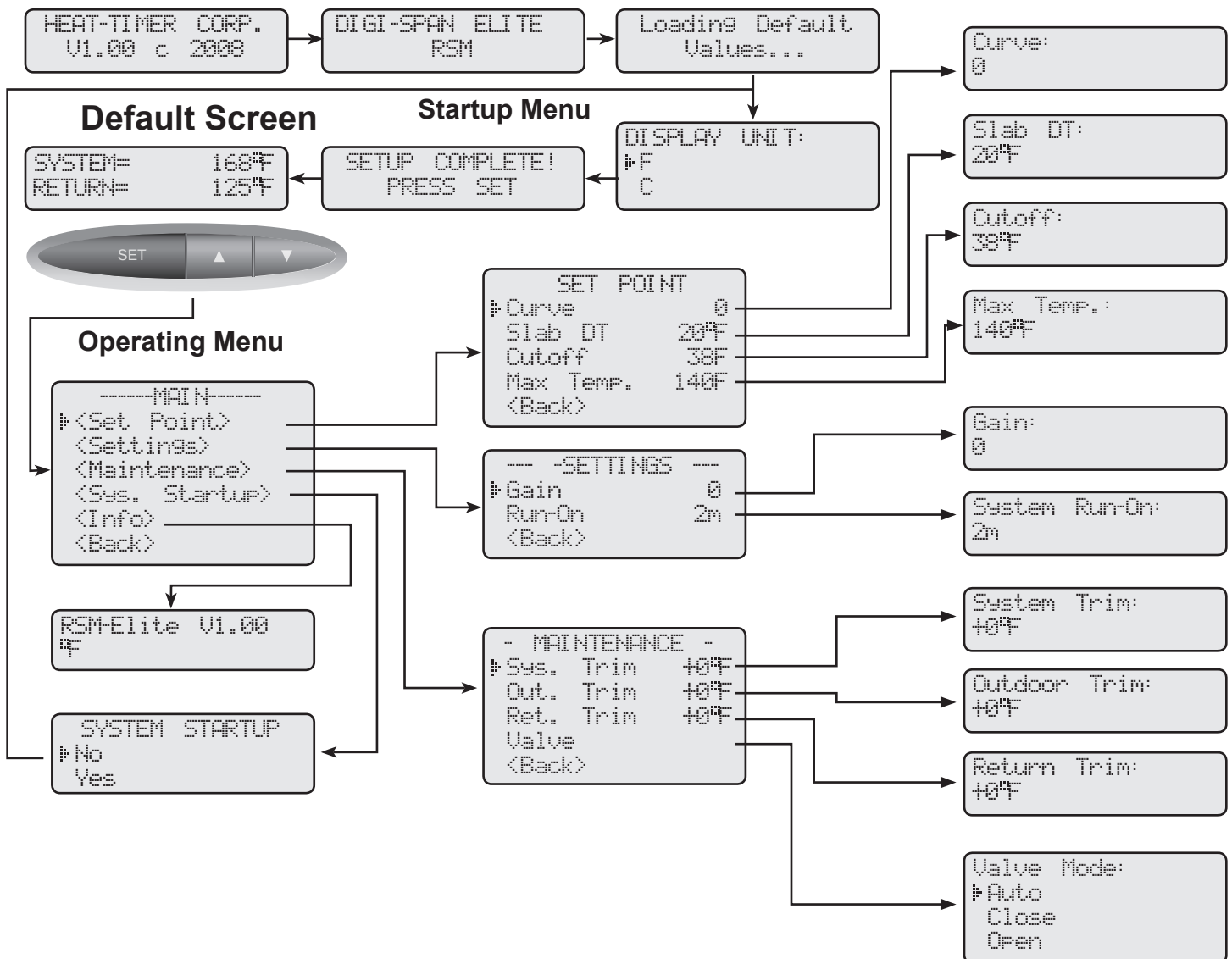

Startup Options

When the control is initiated for the first time or after a manual reset, it will start its operation with the Startup Menu. Later, the Startup menu can be accessed as an option from the operation menu. An option must be accepted in each screen in the Startup Menu to move to the next level.

Display Unit

Options: °F, °C

Default: °F

 /<System Startup>/Display Unit

- The RSM-Elite will offer two different temperature displays. If °F is selected, all temperatures will display in Fahrenheit. If °C is selected, all temperatures will display in Celsius.

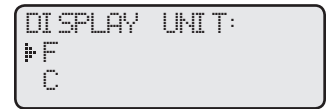

Setting the Control to Factory Default

To Reset the RSM-Elite control to its original factory defaults, power down the control. Hold down the SET and DOWN buttons while powering the control back up until the Loading Default Values screen appears. The display will direct you to the Startup menu after the defaults are loaded to program the control.



NOTE: When resetting the control to original factory defaults, check all settings, as they will be over written.

Default Display

The default display will show the current System temperature and the Return temperature. In addition, by clicking the **Up** or **Down** button, the display will show the current Outdoor temperature and the current Return Target temperature.

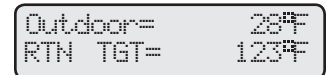

Operating Menu Options

(Click SET Button )

Curve

Options: From -10 to +10

Default: 0

 /<Set Point>/Curve

- The Curve adjusts the final Return Target based on the outdoor temperature. See Return Target Table on page 6.
- A higher Curve number will result a higher Return Target for the same outdoor temperature.
- The best curve is the one with the lowest number that can still melt the snow. Thus, provide the best snow melting efficiency for that slab.
- When precipitation is expected, start the slab heating system and let it run at least 24 hours. This time is needed to allow the slab temperature to reach the melting point.
- When the precipitation begins and after a full 24 hour warm-up period, monitor the slab. Check if the precipitation is beginning to accumulate or if it melts immediately.
- If there is accumulation, the slab temperature is too low. Increase the Curve value by one number (for example, from 0 to 1).
- If the precipitation is melting immediately, the slab may be using more energy than it needs. Decrease the Curve value by one number (for example, from 0 to -1).
- After making a change in the Curve value, wait at least four hours to see what affect this change will have on the slab.
- Repeat the above procedure as necessary until the lowest Curve value which still melts precipitation is determined.

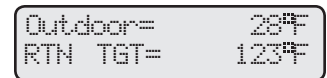
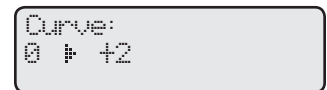

Return Target Temperature Table

		Outdoor Temperature °F									
		35	30	25	20	15	10	5	0	-5	-10
Curve	-10	33	40	48	55	63	70	78	85	93	100
	-9	36	44	52	60	67	75	83	91	98	106
	-8	40	48	56	64	72	80	88	96	104	112
	-7	44	52	60	69	77	85	93	102	110	118
	-6	48	56	65	73	82	90	99	107	116	124
	-5	51	60	69	78	86	95	104	113	121	130
	-4	55	64	73	82	91	100	109	118	127	136
	-3	59	68	77	87	96	105	114	124	133	142
	-2	63	72	82	91	101	110	120	129	139	148
	-1	66	76	86	96	105	115	125	135	144	154
	0	70	80	90	100	110	120	130	140	150	160
	1	74	84	94	105	115	125	135	146	156	166
	2	78	88	99	109	120	130	141	151	162	172
	3	81	92	103	114	124	135	146	157	167	178
	4	85	96	107	118	129	140	151	162	173	184
	5	89	100	111	123	134	145	156	168	179	190
	6	93	104	116	127	139	150	162	173	185	196
7	96	108	120	132	143	155	167	179	190	202	
8	100	112	124	136	148	160	172	184	196	208	
9	104	116	128	141	153	165	177	190	202	214	
10	108	120	133	145	158	170	183	195	208	220	

Slab ΔT

Options: From 5°F/3°C to 50°F/28°C

Default: 20°F/11°C

 /<Set Point>/Slab DT

- The Slab ΔT is the design temperature difference between the slab supply temperature and the slab return temperature of the heating fluid. It is set to prevent too much heat from entering the slab in a short time. Since, if large amounts of energy transferred to the slab exceeds a safe limit, the slab may get damaged.
- This value is normally provided by the slab design engineer and must be adjusted to that setting to prevent from damaging the slab.
- During the warm-up period, the RSM-Elite will modulate the motorized valve to regulate the amount of energy entering the slab based on that setting. If that value is reached, the control will modulate the motorized valve close to prevent sudden increases in slab temperature.
- If the design Slab ΔT is unknown, set it to the smallest possible value.

Slab DT:
20°F ± 25°F

⚠ WARNING

The adjustment of the Slab ΔT to higher than the slab design might crack the slab during the heating process.

Outdoor Cutoff

Options: Off, 20°F/-6°C to 50°F/10°C, On

Default: 38°F/3°F

 /<Set Point>/Outdoor Cutoff

- The Outdoor temperatures can be viewed from the default screen by clicking the Up or Down buttons.
- When the outdoor temperature falls to the adjustable Outdoor Cutoff temperature, the RSM-Elite will control the System Pump and Motorized valve relays to heat the slab.
- When the outdoor temperature rises to the Outdoor Cutoff plus a 2°F differential, the RSM-Elite will energize the Motorized Valve Close relay for 6 minutes to guarantee valve closure. This will prevent the slab from getting heated during warmer outdoor temperature. The System relay will remain energized for the Run-On delay.

Cutoff:
38°F ± 35°F

- In addition to the Outdoor Cutoff temperature setting range, it can be set to **ON** or **OFF**. If **ON** is selected, the System Relay will energize regardless of the Outdoor temperature and the RSM-Elite will control the motorized valve to hold the Return target temperature. If **OFF** is selected, the System and Open relays will always be off.

Maximum Temperature

Options: From 70°F/21°C to 180°F/82°C

Default: 140°F/60°C

```
Max Tempt:
140°F | 120°F
```

 /<Set Point>/Max Temp

- This is the highest water temperature the RSM-Elite will circulate through the slab.
- It should be set according to the slab design specification to avoid slab damage.
- Regardless of the other settings, the RSM-Elite will not allow the supply temperature to exceed this setting. Thus, the Return will be significantly less than this setting.
- The RSM-Elite will regulate the slab supply water temperature not to exceed the Maximum Temperature. However, if that value is reached, the control will modulate the motorized valve close relay to prevent excessive increases in slab temperature.

WARNING

The Maximum Temperature setting **MUST NOT** be set higher than the slab design temperature to avoid slab damage.

Gain

Options: From -10 to +10

Default: 0

```
Gain:
0 | 2
```

 /Settings>/Gain

- The Gain adjusts the aggressiveness of the RSM-Elite PID logic to control how much modulation is changed when the slab supply and return temperatures change.
- A Gain of 0 is a good starting point for all systems.
- If during normal load conditions, the system value tends to oscillate, decrease the Gain by two numbers (for example, from 0 to -2). Wait for at least 15 minutes before evaluating how the change has affected the system.

Run-On

Options: From 0 min to 60 min **Default:** 2 min

```
Pump Run-On:
2m | 6m
```

 /Settings>/Run On

- The System relay will energize whenever the Outdoor temperature is below the Outdoor Cutoff. When the Outdoor temperature increases 2°F above the Outdoor Cutoff, the System relay will stay on for a period set by the Run-On. This allows the Pump to dissipate the residual heat within the system back into the building.
- The Run-On time should be set based on the size of the boiler and pump.

Slab Supply, Slab Return, and Outdoor Sensor Trim

Options: From -20°F/-11°C to +20°F/+11°C **Default:** 0F/0C°

```
System Trim:
+0°F
```

 /<Maintenance>/Sys. Trm, Out. Trim, or Ret. Trim

- The Heat-Timer sensors are very accurate. However, sometime it might be beneficial to adjust the values to match an existing sensor. The Slab Supply, Slab Return, or Outdoor Trim value adjust the respective Sensor reading using positive or negative values.

```
Outdoor Trim:
+0°F
```

```
Return Trim:
+0°F
```

Valve Mode

Options: Auto, Close, Open **Default:** Auto

 /<Maintenance>/Valve

- The Auto option allows the RSM-Elite to modulate and pulse the valve open or close to achieve a specific target temperature.
- The Close option will energize the Close relay constantly. This option can be used during equipment repairs and testing. This display will read `MANUAL CLOSE`.
- The Open option will energize the Open relay constantly. In addition, the System relay will remain energized. This option can be used during equipment repairs and testing. This display will read `MANUAL OPEN`.

```
Valve Mode:
#Auto
Close
Open
```

```
SYSTEM=      55°F
MANUAL CLOSE
```

```
SYSTEM=      55°F
MANUAL OPEN
```

Enable/Disable Input

- The RSM-Elite will heat the slab only if the *EXT±* terminals are shorted. These terminals must be connected to external equipment or switch to start the operation when needed. See Wiring the Enable/Disable on page 4.
- When the *EXT±* terminals are `OPEN`, the Target will display `TSTAT OPEN`. When they are shorted, the heating of the slab will start..

NOTE: On a sensor fault while the *EXT±* terminals are shorted, the control will close the valve and display `SENSOR FAILURE`. However, the system pump will remain energized until either the Outdoor Cutoff is exceeded or the *EXT±* Terminals are opened.

```
SYSTEM=      70°F
TSTAT OPEN
```

```
SYSTEM=      OPEN
SENSOR FAILURE
```

RSM-Elite Mechanical and Electrical Diagrams

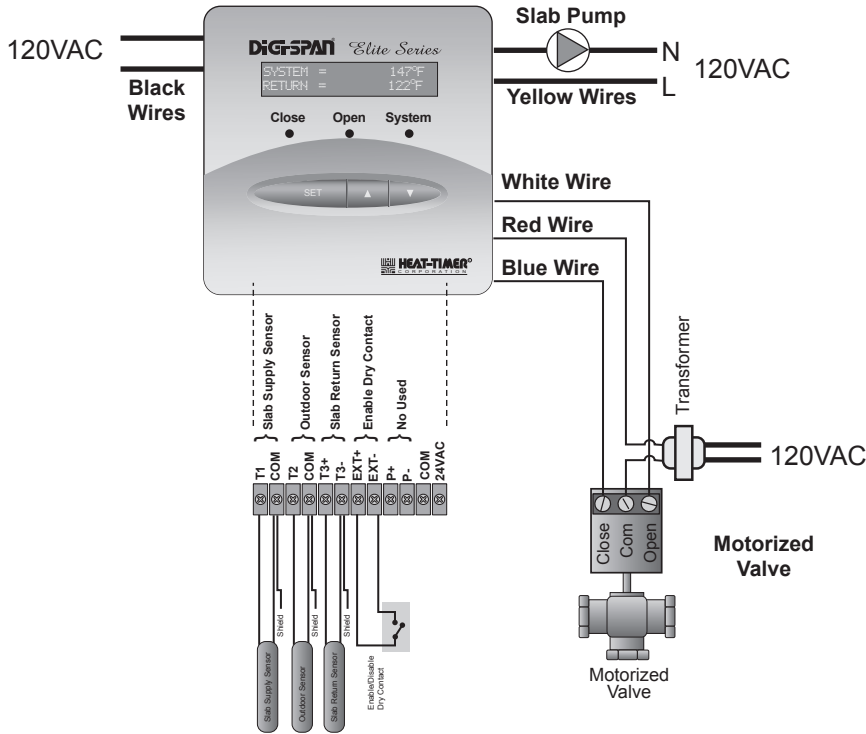

Mechanical

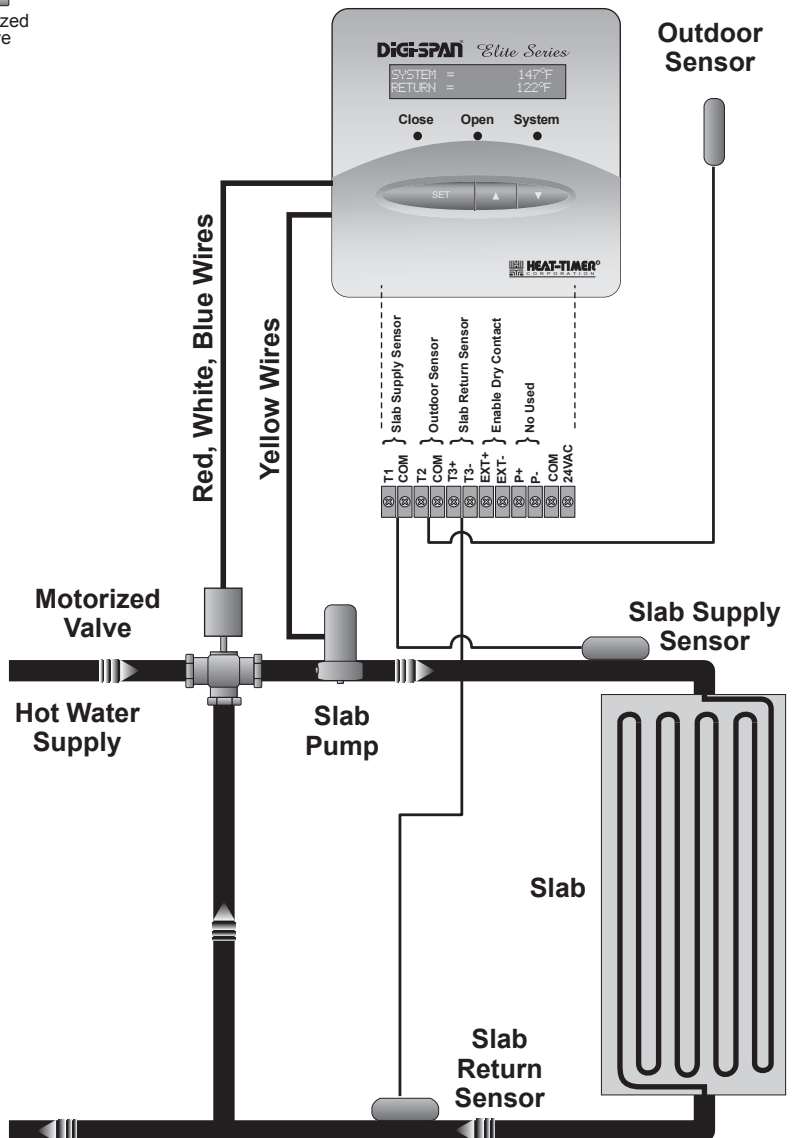

Troubleshoot

Temperature Sensor Chart

No Display or LED Lights

Check the power to the RSM. The RSM-Elite requires 120VAC power to the Black wires or 24VAC to the right most terminals. Turn the power off and back on to restore the display. If unsuccessful, make sure the Display Cover of the control is securely mounted to the Base.

System or Outdoor Reads OPEN or SHORT

If Open, short the sensor input terminals. The display should read **Short**. If it does, check the sensor wiring. If it doesn't, the RSM-Elite may be damaged.

If Short, remove the wires from the input terminals. The display should read **Open**. If it does, check the sensor wiring. If it doesn't, the RSM-Elite may be damaged.

System or Outdoor Reads an Incorrect Temperature

Remove the wires from the input terminals. The display should change to read **Open**. If it doesn't, the RSM-Elite may be damaged. Otherwise, take an ohm reading across the detached sensor wires. The ohm reading should correspond to the Temperature Sensor Chart. If the difference is within 5°F adjust the Trim of the sensor. Otherwise, the sensor may be damaged.

No Heat - All LEDs are OFF

- **Outdoor Cutoff** - Check the outdoor temperature and Outdoor Cutoff readings. If the outdoor temperature is above the Outdoor Cutoff, the RSM-Elite will not give heat. The display will show **OUTDOOR CUTOFF**. See Outdoor Cutoff on page 6.
- **Tstat Open** - If the display shows **TSTAT OPEN** then, check the **EXT±** terminals. If the **EXT±** terminals are not jumped together, the RSM-Elite will not give heat. See Enable/Disable Input on page 8
- **Valve Manually Closed** - Finally, if the display shows **MANUAL CLOSE** then, the Valve Mode has been set to Close. Change Valve mode to Auto. See Valve on page 8.

No Heat - System Pump LED ON - Pump Not Running

Remove any connections to the Yellow wires for the Heating System Pump. Test for continuity across the pair of Yellow wires. If the meter registers continuity, the RSM-Elite is calling for the Slab Pump to run and the problem is not with the RSM. Check the pump power source. Note that the RSM does not source power to the outputs. See Pump Wiring on page 3.

RSM-Elite Does Not Move the Floating Motorized Valve

- **First check the valve wiring** - The RSM-Elite does not source power to the actuator. Instead, a separate power source must be wired to the actuator as shown on page 3 for the floating output.
- **Check relay operation** - Remove any wires connected the actuator. Set the Valve mode to Close and check for continuity across the Red and Blue and across Red and White wires. The meter should register continuity across the Red and Blue and should register no continuity across the Red and White. Otherwise, the RSM-Elite may be damaged. Then, set the Valve mode to Open and check for continuity across the Red and Blue and across Red and White wires.. The meter should register no continuity across the Red and Blue and should register continuity across the Red and White. Otherwise, the RSM-Elite may be damaged.
- **Valve Manually Closed** - Finally, if the display shows **MANUAL CLOSE** then, the Valve mode has been set to Close. Change Valve mode to Auto. See Valve on page 8.

Snow Does not Melt or Slush is on the Ground

- **Start Slab Melting 24 Hour Early** - If the slab heating system has not been active for at least 24 hours, the slab temperature may not be warm enough to melt the snow. It is recommended to activate the heat to the slab at Least 24 hours before the snow.
- **Adjust the Curve** - If the snow accumulation occurs in colder temperature, then increase the Curve setting. See Curve on page 5.
- **Outdoor Cutoff** - Check the outdoor temperature and Outdoor Cutoff readings. If the Outdoor Cutoff is set too low, the RSM-Elite will not give heat. Increase the Outdoor Cutoff above the current outdoor temperature. See Outdoor cutoff on page 6.

TEMPERATURE (in Degrees °F)	Value (in Ohms)
-30	117720
-20	82823
-10	59076
0	42683
10	31215
20	23089
25	19939
30	17264
35	14985
40	13040
45	11374
50	9944
55	8714
60	7653
70	5941
80	4649
90	3667
100	2914
110	2332
120	1879
130	1524
140	1243
150	1021
160	842
170	699
180	583
190	489
200	412
210	349
220	297
230	253
240	217
250	187

RSM Specifications

Voltage Input:	120 VAC 60 Hz(2 Black wires) /24VAC 60 Hz (24VAC terminals) (Only One Power Source)
Power Consumption:	3 VA Max
Operating Temperature:	20°F to 120°F
Operating Humidity:	20% to 80%
Dimensions:	4"W x 4"H x 2½"
Weight:	1 pound
Display:	Back Lite 2 Line Alphanumeric LCD Display
Display Units:	Fahrenheit (°F) and Celsius (°C)
Outputs:	3 S.P.S.T (Yellow = System Pump.), (White = Open MOV.), (Blue = Close MOV), (Red = Common MOV)
Output Relay Ratings:	1 Amp inductive (Maximum of 1/8 HP), 6Amp resistive at 120 VAC 60 Hz
Curve:	from -10 to +10
Slab ΔT:	5°F (3°C) To 50°F (28°C)
Maximum Temperature:	from 70°F (21°C) to 180°F (82°C)
Outdoor Cutoff:	from 20°F (-7°C) to 50°F (10°C), On, Off
Pump Run-On:	from 0 to 60 minutes
Valve Mode:	Auto, Close, Open
Gain:	from -10 to +10
LED:	3 representing the Output relays (Left=Close, Middle=Open, Right=System Pump)
Inputs:	3 Temperature Sensors (Slab Supply, Slab Return, and Outdoor), and Enable/Disable input
Buttons:	3 (Set, Up, Down)
Enable/Disable:	Terminals EXT+, EXT-