

Remarkable Control... Safety Sensitive

**TEMPERING VALVES
FOR DOMESTIC HOT WATER
APPLICATIONS**

**ELECTRONIC
TEMPERING
VALVE**



**PRECISION
TEMPERING
VALVE**



**TEMPERATURE
MONITORING
CONTROL**



 **HEAT-TIMER**[®]
CORPORATION

20 New Dutch Lane, Fairfield, NJ 07004
973-575-4004 • Fax 973-575-4052 • <http://www.heat-timer.com>

PRECISION TEMPERING VALVE

Description

When precise water temperature control is critical, Heat-Timer's Tempering Valve is the solution

This valve provides the most accurate water temperature under all conditions, even at very low flows with as little as a 1 PSI pressure drop. And this accuracy can be achieved with the valve installed in any position, vertically, horizontally, or diagonally.

Heat-Timer's Tempering Valve is ideal for any application where domestic hot water must be controlled at all times and under all conditions.

Typical uses include:

- Hospitals, nursing homes, and other institutional facilities
- Apartment buildings and condominiums
- Hotels, motels, and other lodging establishments

Precision Tempering Valves provide the highest level of temperature control for Domestic Hot Water applications

The valve's unique design is deceptively simple. An internal thermostatic element mechanically adjusts the amount of cold and hot water entering the valve so the desired outlet water temperature is maintained. This is done automatically and virtually instantaneously, without any electronic components and without restrictive piping and pressure drop requirements. This is possible because the valve includes an extra-long thermostat whose large heat-transfer surface enables consistent output accuracy, even under very low flow conditions.

The Tempering Valve also offers superior reliability. The valves are cast of heavy-duty bronze and machined by state-of-the-art equipment to exact tolerances. With no electronic and few moving components, the valves will provide years of reliable service. And, if internal parts do eventually wear out, the modular design enables them to be easily field replaceable, more than doubling the effective valve life compared to competitors.



ASSE Listed

TEMPERING VALVES SUBMITTAL SHEET

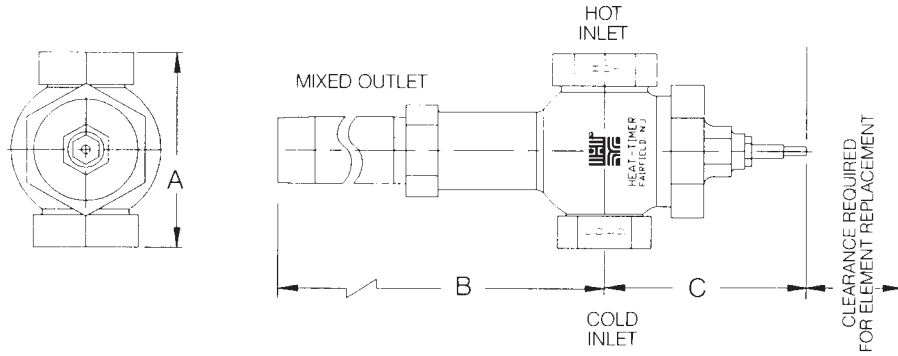

Pressure Drop Flow Chart/Pressure Loss (P.S.I.)

Valve Size	1 P.S.I.	2 P.S.I.	5 P.S.I.	10 P.S.I.	15 P.S.I.	20 P.S.I.
1/2"	4	6	9	14	17	19
3/4"	5	7	12	16	19	22
1"	7	9	15	20	24	29
1 1/4"	12	17	27	38	44	52
1 1/2"	14	19	29	41	48	57
2"	20	31	65	91	110	130
2 1/2"	51	70	115	170	190	226
3"	59	78	131	183	209	251
4"	92	135	217	296	373	405

Gallons Per Minute

For Safety Applications See Heat-Timer Control System Model #926640-00 (Temperature Monitoring Control)

The Heat-Timer Tempering valve is a primary tempering valve and is not designed or recommended to be used as a "Failsafe or anti-scald" valve.

Specifications & Dimensions

Valve Size	PART NO.	A	B	C	Clearance For Element Replacement	STANDARD PIPE TAP		
						MIXED OUTLET	HOT INLET	COLD INLET
1/2"	910520-00	4 1/2"	8"	4 1/2"	7"	1/2"	1/2"	1/2"
3/4"	910521-00	4 1/2"	8"	4 1/2"	7"	3/4"	3/4"	3/4"
1"	910522-00	4 1/2"	11 1/4"	4 1/2"	12"	1"	1"	1"
1 1/4"	910523-00	4 3/4"	19"	5"	19"	1 1/4"	1 1/4"	1"
1 1/2"	910524-00	5 1/2"	23"	5"	24"	1 1/2"	1 1/2"	1 1/4"
2"	910525-00	6 3/8"	25"	6"	24"	2"	2"	1 1/2"
2 1/2"	910526-00	7 1/2"	27 3/4"	6"	28"	2 1/2"	2 1/2"	2"
3"	910527-00	9"	29 1/8"	6 1/2"	28"	3"	3"	2 1/2"
4"	910528-00	10 1/4"	31"	7"	28"	4"	4"	4"

ENG. _____

GPM _____

JOB # _____

ΔP _____

JOB ADDRESS _____

HEAT-TIMER® TEMPERING VALVE

SIZE _____

PART # _____

Heat-Timer Tempering Valve

- Can be sized with as little as 1 P.S.I. Drop.
- Only one Heat-Timer Tempering Valve is required to maintain accuracy at high and low flows.
- Replaceable internal bore.
- Standard outlet temperature range: 100°F - 180°F
- The Heat-Timer Tempering Valve can be installed in any position.
- It is not necessary to trap the valve below the water line of the hot water supply source.
- Though the Heat-Timer Tempering Valve can be installed in any location, it is imperative that the installation guidelines and application diagrams are followed.

ASSE Listed

ELECTRONIC TEMPERING VALVE

ETV

Description

When water temperature control and convenient operation are needed, the ETV delivers

This electronic tempering valve accurately regulates water temperature for a wide variety of applications. The large, easy-to-read display and user-friendly adjustment module can be located conveniently, up to 500 feet from the valve. This allows outlet water temperature to be monitored at a glance and for the temperature to be adjusted without having to access the valve piping.

The ETV is ideal for any application where water temperature must be accurately controlled. Typical uses include:

- Domestic hot water temperature control
- Heating and cooling applications
- Industrial processes

Accurate and Easy

The ETV combines a rugged bronze valve body, reliable electronic actuator, and a control module with PID-type logic. The control module constantly monitors the outlet temperature of the valve. This temperature is displayed in 1/2" LED digits that can be read across the room in virtually any lighting conditions. Based on the set point, which is user-adjustable in 1° increments, the control employs PID-type logic to adjust the signal sent to the actuator. The actuator mounts directly to valve body

and mixes the hot and cold water required to produce the desired outlet temperature. The PID-Type control quickly restores the desired water temperature, even after large changes in load conditions, with a minimum of fluctuation. This makes the ETV ideal for applications with sudden load shifts or where an outlet water return cannot be piped into the cold water supply of the valve challenging applications in the same inexpensive, easy-to-use package. The ETV can also accept a switch or time clock signal to incorporate set back.



ETV Package Includes

- Control Module (w/transformer)
- Valve Body
- Valve Motor & Frame
- Temperature Sensor

UL - Listed

ELECTRONIC TEMPERING VALVE SUBMITTAL SHEET

SPECIFICATIONS

Input Voltage:..... 120VAC 60Hz
Power Consumption: 16VA (Total)
 ETV Control: 1VA@5V
 Valve Unit:..... 15VA@24V
Output on Terminals 1 and 2:24VAC, 15VA (Max) -
 polarity sensitive
Output on Terminals 3 and 4: 0 to 10V (Max), 100mA (Max) - polarity
 sensitive
Setback Inputs on Terminals 8 and 7:.....Dry-contact switch only
 Adjustable 1°F to 50°F (1°C to 28°C)
Setpoint Range 60°F to 180°F
Temperature Inputs on Terminals 6 and 7:.....Use Heat-Timer
 Gold Sensor
 Sensor Ranges:..... -30°F to 250°F (-35°C to 120°C)
 Sensor Accuracy:..... +/- 2°F (1°C)
 Set Point:60°F to 180°F (16°C to 82°C)
Temperature Display:..... Field Select F/C
Operating Ambient Temperature:
 ETV Control:32°F to 158°F (0°C to 70°C)
 Valve Unit:..... 14°F to 122°F (-10°C to 50°C)

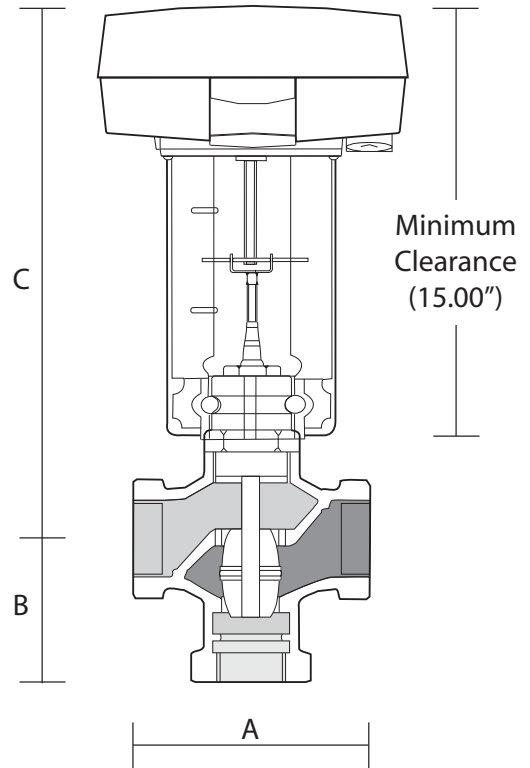

Electronic Tempering Valve Sizing Chart

Pressure Drop	Valve Size					
	1/2"	3/4"	1"	1-1/4"	1-1/2"	2"
3 psi	8	12	20	32	50	80
4 psi	9	15	23	37	58	93
5 psi	10	16	26	41	64	103
6 psi	12	18	28	45	71	113
7 psi	13	20	31	50	78	125
8 psi	14	21	33	53	83	132
9 psi	15	22	35	56	88	140
10 psi	16	23	36	58	91	145
11 psi	17	24	38	62	97	154
12 psi	18	25	40	64	100	160

Gallons Per Minute

Sizing Recommendations:

To maintain accuracy, we recommend you select a valve size with a design flow rate as close as possible to a 5 psi drop.

Minimum Pressure Drop:

We recommend that you do NOT select a valve size with less than a 3 psi drop across the valve.

Maximum PSI Drop:

We recommend that you do NOT select a valve size that exceed a 12 psi drop across the valve.

Specifications & Dimensions

Valve Size	PART NO.	A	B	C	INLET/OUTLET PIPE SIZES		
					MIXED OUTLET	HOT INLET	COLD INLET
1/2"	915520-00	3 1/4"	2 3/4"	16 1/2"	1/2"	1/2"	1/2"
3/4"	915521-00	3 1/4"	2 3/4"	16 1/2"	3/4"	3/4"	3/4"
1"	915522-00	4 1/4"	2 7/8"	17"	1"	1"	1"
1 1/4"	915523-00	4 3/4"	2 7/8"	17"	1 1/4"	1 1/4"	1 1/4"
1 1/2"	915524-00	5 3/4"	3"	17 1/2"	1 1/2"	1 1/2"	1 1/2"
2"	915525-00	6 1/2"	3 1/2"	17 1/2"	2"	2"	2"

For Safety Applications See Heat-Timer Control System Model #926640-00 (Temperature Monitoring Control)

The Heat-Timer Tempering Valve is a primary tempering valve and is not designed or recommended to be used as a "Failsafe or anti-scald" valve.

ENG. _____ GPM _____
 JOB # _____ ΔP _____
 JOB ADDRESS _____ HEAT-TIMER® ELECTRONIC TEMPERING VALVE
 SIZE _____
 PART # _____

UL - Listed

TEMPERATURE MONITORING CONTROL

Safeguard Against Extreme System Conditions

TMC

Description

When temperature monitoring[♦] is critical, the TMC brings greater peace of mind.

In addition to providing an alarm whenever temperature reaches a critical point, when incorporated with a solenoid valve, the TMC effectively interrupts system activity until the problem is resolved.

The TMC is ideal for any application that requires vigilant system monitoring. Typical uses include:

- Domestic hot water monitoring, especially in hospitals, nursing homes, and other commercial and institutional facilities
- Low temperature monitoring, such as commercial or industrial refrigeration systems and freezers
- Industrial applications which require tight monitoring of temperature, pressure, or humidity
- Any space temperature monitoring which might require an alarm

TMC & Tempering Valve Combination Significantly Decreases the Risk of Scalding

The TMC is commonly used as an extra layer of protection in domestic hot water systems that use tempering valves. When temperatures reach a critical point in a domestic hot water system, the TMC activates an alarm and closes a solenoid valve, shutting down the flow of hot water into the system. Since the TMC includes an integral “latching” relay (manual reset), the problem must be resolved before the valve will open. In fact, two things must occur before normal operation resumes:

- (1) The domestic water temperature must fall below the critical point
- (2) The TMC’s manual reset button must be pressed. By resetting, you allow the solenoid valve (NC) to flow hot water to the tempering valve.

The TMC is also equipped with a second output for alarm. This output can be linked to the Heat-Timer Visual/Audio alarm, which uses both a red light and buzzer to indicate alarm status. It can also be linked directly into a Heat-Timer control panel, Notifact, or Energy Management System to provide remote alarm capability.



[♦]TMC may also be ordered for pressure or humidity monitoring

UL - Listed

TEMPERATURE MONITORING CONTROL SUBMITTAL SHEET

SPECIFICATIONS

Input Voltage 120VAC
Power Consumption 20VA Max
Operating Mode Heating or Cooling
Output DPDT
Output Rating 6A 1/3HP
Accuracy + 1°F (1°C)
Operating Ambient Temp 20 to 120°F
Sensor Range -30 to 250°F (-35 to 120°C)
Set Point Range -30 to 250°F (-35 to 120°C)
Enclosure
 Dimensions 7 1/8"W x 9 5/8"H x 3 1/2"D
 Material UV Resistant ABS Gray (NEMA 1)

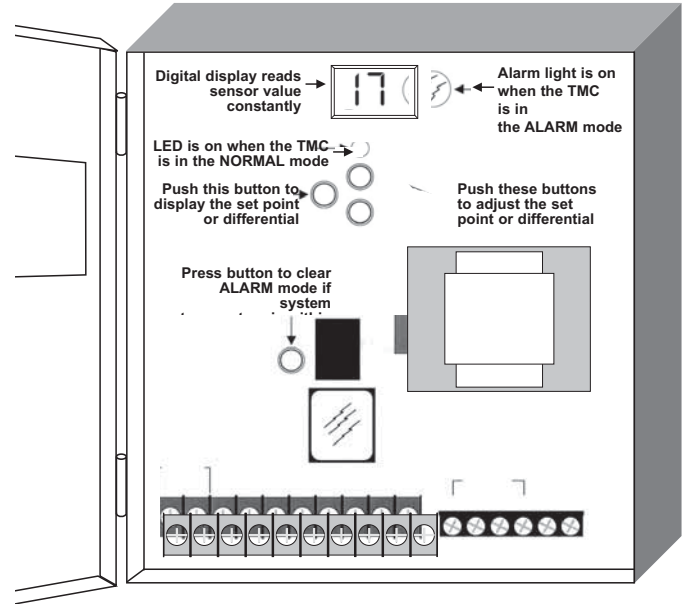

“TEMPERATURE MONITORING CONTROL” WITH HEAT-TIMER ELECTRONIC TEMPERING VALVE

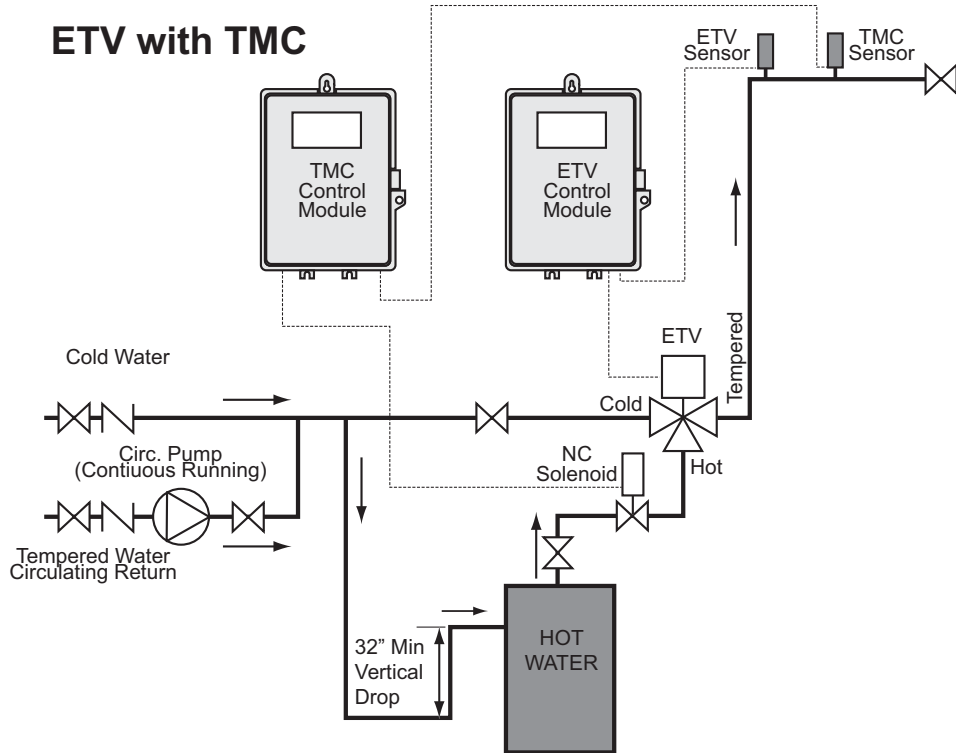

ENG. _____ GPM _____
 JOB # _____ ΔP _____
 JOB ADDRESS _____ HEAT-TIMER® TEMPERING VALVE
 _____ SIZE _____
 _____ PART # _____

UL - Listed

TYPICAL PIPING DIAGRAMS FOR TEMPERING VALVE AND ELECTRONIC TEMPERING VALVE

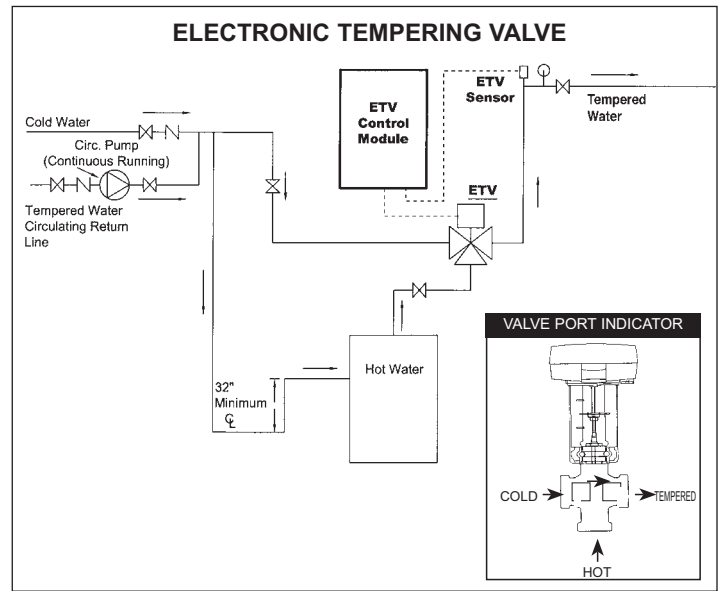
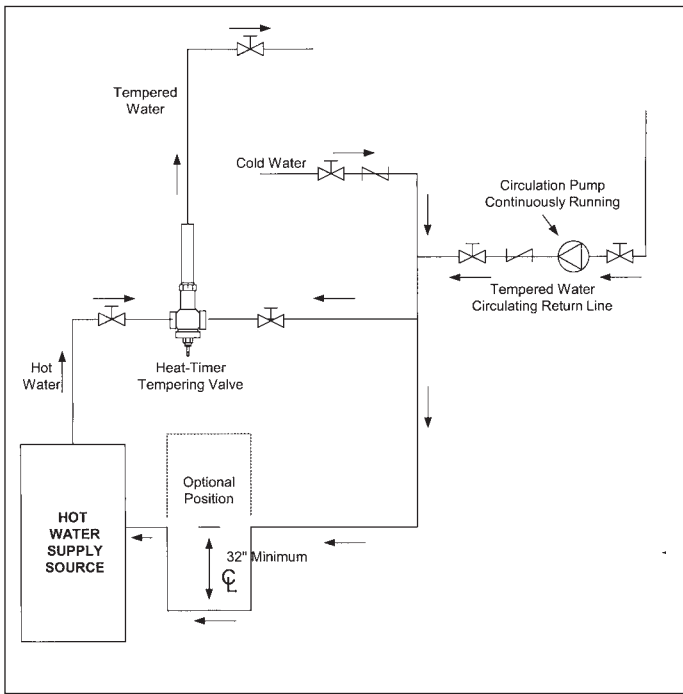

ORDERING INFORMATION

Electronic Tempering Valve (ETV)

Includes:

- Control module with transformer
- Bronze Valve Body
- Valve Motor & Frame
- Temperature Sensor

Valve Size	Part No.
1/2"	915520-00
3/4"	915521-00
1"	915522-00
1 1/4"	915523-00
1 1/2"	915524-00
2"	915525-00

Tempering Valve

Valve Size	Part No.
1/2"	910520-00
3/4"	910521-00
1"	910522-00
1 1/4"	910523-00
1 1/2"	910524-00
2"	910525-00
2 1/2"	910526-00
3"	910527-00
4"	910528-00

Temperature Monitoring Control (TMC)

Includes Control Module & Temperature Sensor
Solenoid Valves Sold Separately

Part No.	Description
926640-00	TMC - Temperature Monitoring Control
926641-00	TMC- with Battery Backup
925011-00	Audio Visual Alarm Add-On

Part No.	Solenoid Valve Size	C _v
920520-00	1/2"	4.6
920521-00	3/4"	9.3
920522-00	1"	12.3
920523-00	1 1/4"	21
920524-00	1 1/2"	28
920525-00	2"	46.7