

INSTALLATION/OPERATING INSTRUCTIONS

DIGI-SPAN[®]

SPC PRESSURE

Digital Set Point Control

Ranges 0-30, 0-100, and 0-200psi

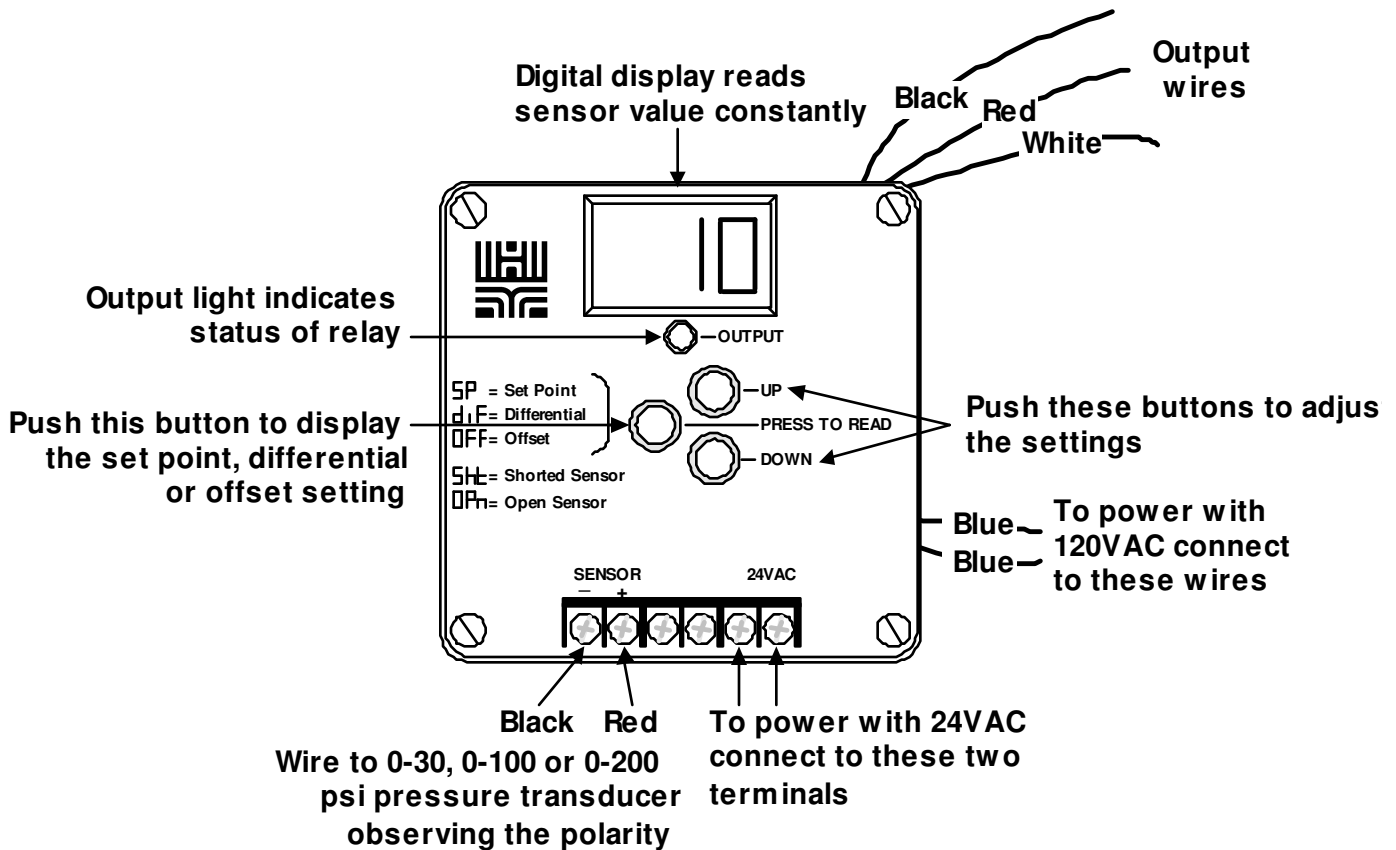

Warning: This Heat-Timer[®] control is strictly an operating control; it should never be used as a primary limit or safety control. All equipment must have its own certified limit and safety controls required by local codes. The installer must verify proper operation and correct any safety problems prior to the installation of this Heat-Timer control.

LIMITED ONE YEAR WARRANTY

This Heat-Timer device was thoroughly tested for defects and workmanship before leaving our factory. We do warrant the equipment to be free of defects under normal use for a period of one year from the date of installation. Transportation charges for factory repairs must be prepaid. Damage to the Heat-Timer device or any of its components due to misuse, abuse, improper installation, or caused by power failures, fire, flood, or lightning are not covered by this warranty. The company assumes no liability for indirect or consequential damages of any nature. This Heat-Timer warranty applies only to the original purchaser/user, is not assignable or transferable, and does not cover damage to the device occurring in shipment. Any service, repairs, modifications or alterations to the unit not expressly authorized by the company will invalidate the warranty. This warranty is in lieu of all other warranties expressed or implied.

INSTALLATION

Mounting the Controller

- The SPC is designed to mount on a 1900 (4"x4") electrical box.
- If the SPC is to be panel mounted, or if additional room is needed for wiring, an extension skirt is available.*
- Locate the SPC in a convenient location near the unit to be controlled.
- Mount the SPC away from excessive heat or cold. Ambient operating temperature is from 20 to 120°F.
- After completing all the wiring connections (see below) use the two screws provided to mount the SPC to the 1900 box.

Installing the Pressure Sensor

- Attach a 1/4" brass isolation tube (pigtail) to the steam header.
- Screw the pressure sensor to the pigtail. The sensor has 1/4" NPT tapered threads.
- The BLACK and RED sensor wires can be extended up to 500' by splicing with 18 gauge shielded wire. Any other sensor wires (green, white, or shield) and the tube are not used and do not need to be extended.
- Do not run wires in conduit with line voltage.
- The SPC will operate based on the pressure it reads at the sensor location. Therefore, select a sensor location which is representative of the entire system.

Wiring the Sensor

- The BLACK wire from the pressure transducer should be connected to the terminal marked *SENSOR -*.
- The RED wire from the pressure transducer should be connected to the terminal marked *SENSOR +*.
- The transducer wires can also be connected to the back of the SPC using the Rear Wire connector*. Connect the BLACK sensor wire to yellow Rear Wire and the RED sensor wire to the orange Rear Wire.

Wiring the Power - SPC can use either 120VAC or 24VAC

120VAC

- Attach line voltage to the two blue wires extending from the back of the SPC.
- Use wire nuts, or wrap the connections with electrical tape.
- Class 1 voltages must enter the enclosure through a different opening from any Class 2 wiring.

24VAC

- Use a dedicated transformer with at least a 5VA output.
- Bring 24VAC to the two screws on the front of the SPC marked 24VAC.
- 24VAC can also be connected to the rear of the SPC using the Rear Wire connector*. Connect the 24VAC to the violet and gray Rear Wires.

WARNING

The SPC can accept only one source of power: 120VAC or 24VAC. If more than one power source is applied, the unit may be damaged.

TYPICAL WIRING DIAGRAM

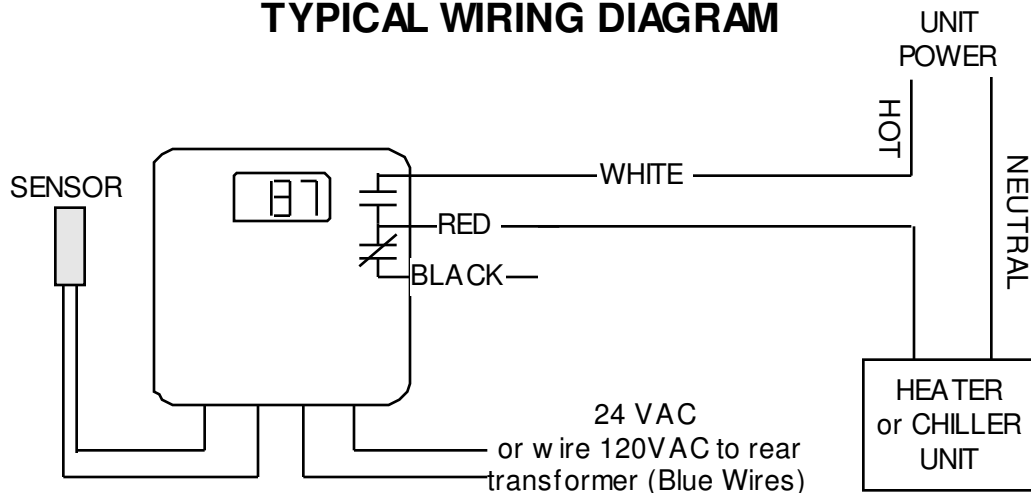

* The Optional Mounting Kit includes the extension skirt, the Rear Wire connector, and an input terminal cover. Order separately as HT #908520.

Wiring the Output

- The SPC has a SPDT (single pole double throw) relay output rated at 10A, 1/8 HP.
- The outputs are dry contacts only. They do not source any power.
- The Red wire is the relay Common.
- The White wire is the N.O. (normally open) relay contact.
- The Black wire is the N.C. (normally closed) relay contact.
- If the output is carrying Class 1 voltages, then it must enter the enclosure through a different opening from Class 2 wiring.

Setting the Operating Modes (Pressure Range, Heating or Cooling)

- Whenever the SPC is powered up, it will display the software version number and then the current operating modes. If the modes are correct, there is no need to make any adjustments.
- Once the modes have been set for a particular application, they will be retained in memory and will not need to be reset.
- Note that if you do change the mode of operation, you will need to reset the set point, differential, and offset.
- To set the operating modes, use the following steps:
 1. Remove power to the SPC (if it was powered) and reapply power.
 2. The display will show the software version number.
 3. Wait approximately 5 seconds and the display will change to read either *30*, *100*, or *200*. If the display shows *30* then the range of the SPC will be from 0 to 30psi and display in 0.5psi increments. If the display shows *100* or *200*, the ranges will be 0 to 100 or 0 to 200psi and display in 1psi increments.
 4. If the correct range is displayed, move on to step 6.
 5. Hold down the center button while pushing either the *UP* or *DOWN* button to select the correct range.
 6. When the correct range is selected, release the buttons and wait approximately 5 seconds.
 7. The display will change to read either *H* or *C*. If the display shows *H* then the SPC will be in a heating mode. The relay will close and the red output light will be on when the pressure is below the set point. If the display shows *C* then the SPC will be in a cooling mode. The relay will close and the light will be on when the pressure is above the set point.
 8. If the desired mode is displayed, move on to step 10.
 9. Hold down the center button while pushing either the *UP* or *DOWN* button to toggle between the displays of *H* and *C*.
 10. When the correct heating or cooling mode is selected, release the buttons and wait approximately 5 seconds. If any changes were made to the operating modes, the display will flash. Then the SPC will display the sensor pressure.

OPERATION

Adjusting the Set Point

- The Set Point determines when the relay will be energized as shown side.
- To adjust the set point, use the following steps:
 1. If you have just powered up the unit, set up the operating modes as described above. If the SPC has been running and is displaying pressure, move on to the next step.
 2. Press the center button and release it. The display will change to show *SP*. Wait 2 seconds or press the *UP* or *DOWN* button and the set point will be displayed.
 3. Press and hold either the *UP* or *DOWN* button until the desired set point is displayed.
 4. Wait approximately 10 seconds. If the set point was changed, the display will flash and then show the sensor pressure. (If you don't want to wait, press the center button 3 times to immediately display sensor pressure).

Adjusting the Differential

- The differential controls how many pounds the system can fluctuate around the set point. It is used to prevent short cycling of the unit being controlled.
- In the heating mode, the relay will energize when the sensor pressure falls to the set point minus the differential. The relay will open when the temperature rises to the set point (see Example).
- In the cooling mode, the relay will energize when the sensor temperature rises to the set point. The relay will open when the pressure falls to the set point minus the differential.

SET POINT and DIFFERENTIAL EXAMPLE

Set Point **10psi** Differential **2psi**

Heating Mode

On a drop to **8psi** Relay Energizes
Output light is **ON**

On a rise to **10psi** Relay Opens
Output light is **OFF**

Cooling Mode

On a rise to **10psi** Relay Energizes
Output light is **ON**

On a fall to **8psi** Relay Opens
Output light is **OFF**

- To set the differential, use the following steps:
 1. If you have just powered up the unit, set up the operating modes (see previous page). If the SPC has been running and is displaying the sensor pressure, move on to the next step.
 2. Press and release the center button twice. The display will change to show *dIF*. Wait 2 seconds or press the *UP* or *DOWN* button and the differential will be displayed.
 3. Press and hold either the *UP* or *DOWN* button until the desired differential is displayed.
 4. Wait approximately 10 seconds. If the differential was changed, the display will flash and then show the sensor pressure. (If you don't want to wait, press the center button once to adjust the offset or twice to display sensor pressure.)

Adjusting the Offset

- The offset value adjusts the sensor pressure reading. It allows you to calibrate the pressure transducer reading by the number of pounds selected.
- To adjust the offset, use the following steps:
 1. If you have just powered up the unit, set up the operating modes (see previous page). If the SPC has been running and is displaying pressure, move on to the next step.
 2. Press the center button three times and release it. The display will change to show *OFF*. Wait 2 seconds or press the *UP* or *DOWN* button and the offset will be displayed.
 3. Press and hold either the *UP* or *DOWN* button until the desired offset is displayed.
 4. Wait approximately 10 seconds. If the offset was changed, the display will flash and then show the corrected sensor pressure. (If you don't want to wait, press the center button once.)

TROUBLESHOOTING

No Display: Check the power to the SPC. The SPC can run off any of the power sources described on page 2. Turn the power off and back on.

OPNDisplay: The SPC does not see a sensor connected. Check the wires are continuous from the sensor to the SPC controller. Check the sensor polarity (see front page). Then follow the procedure for Incorrect Pressure Display.

SHT Display: The SPC sees a short across the input terminals. If you remove the sensor wires from the SPC terminals, the display should change to read *OPN*. If the display does not change to *OPN*, the SPC may be damaged.

Incorrect Pressure Display: Remove the wires from the *SENSOR* screws. The display should change to read *OPN*. If it doesn't, the SPC may be damaged. Use a voltmeter to measure across the *SENSOR* screws. There should be at least 24VDC across the two terminals. If there isn't, the SPC may be damaged. Finally, reconnect the sensor with a mA meter in series with one sensor wire. The mA reading should correspond to the chart at the side. You can use the Offset (see above) to make small adjustments to the pressure reading.

Output Red Light does not come on at the desired

pressure: Check the set point and differential values. In a heating application, the red light will not come on until the pressure drops below the set point minus the differential. In a cooling application, the red light will come on when the pressure rises to the set point.

SPC does not activate the output: First remove all connections to the Red, White, and Black output wires. If the *OUTPUT* red light is on, the relay should be energized; the Red to White wires should be continuous, and the Red to Black wires should be open. If the *OUTPUT* red light is off, the relay should be open; the Red to White wires should be open, and the Red to Black wires should be continuous. If the above two conditions are met, the SPC is working normally; check the unit the SPC is controlling to see why it is not active.

mA	30 PSI	100 PSI	200 PSI
4	0	0	0
4.08			1
4.16		1	2
4.4			5
4.56	1		
4.8		5	10
5.06	2		
5.6	3	10	20
6.13	4		
6.4		15	30
6.6	5		
7.2	6	20	40
8.8	9	30	60
10.4	12	40	80
12	15	50	100
13.6	18	60	120
15.2	21	70	140
16.8	24	80	160
18.4	27	90	180
20	30	100	200

Heat-Timer Corporation
20 New Dutch Lane
Fairfield, NJ 07004

Phone (973) 575-4004 Fax (973) 575 -4052
<http://www.heat-timer.com>

HT 059209-00