

HEAT-TIMER®

INSTALLATION AND OPERATION INSTRUCTIONS

Wireless Programmer for Wireless Sensor System

FOR PLATINUM CONTROLS WITH COMMUNICATION

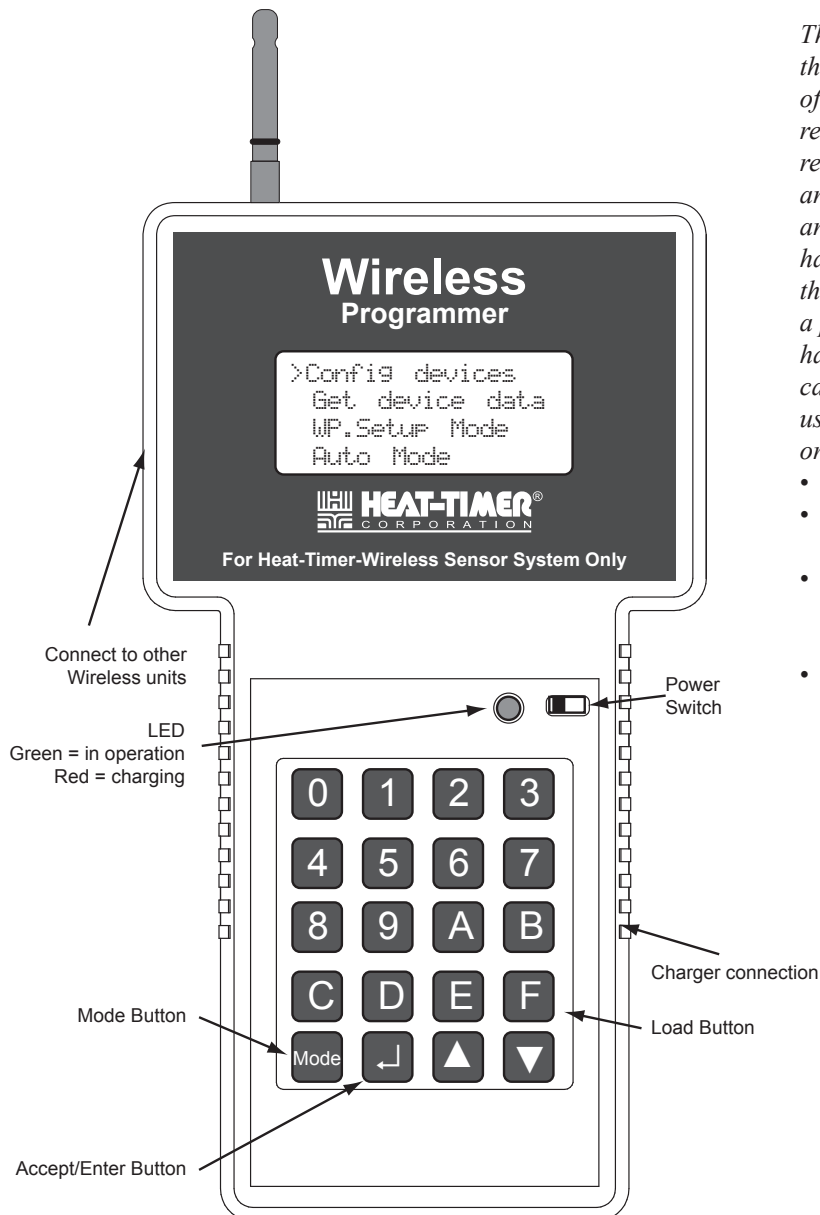

This equipment has been tested and found to comply with the limits for a class B digital device, pursuant to part 15 of the FCC Rules. These limits are designed to provide reasonable protection against harmful interference in a residential installation. This equipment generates, uses and can radiate radio frequency energy and if not installed and used in accordance with the instructions, may cause harmful interference to radio communications. However, there is no guarantee that interference will not occur in a particular installation. If this equipment does cause harmful interference to radio or television reception, which can be determined by turning the equipment off and on, the user is encouraged to try to correct the interference by one or more of the following measures:

- Reorient or relocate the receiving antenna.
- Increase separation between the equipment and wireless Components.
- Connect the equipment into an outlet on a circuit different from that to which the wireless components are connected.
- Consult the dealer or an experienced radio/TV technician for help.

⚠ WARNING

This equipment has been certified to comply with the limits for a class B computing device, pursuant to FCC Rules. In order to maintain compliance with FCC regulation, the antenna(s) used for this transmitter must be installed to provide a separation of at least 8" from all persons and must not be collocated or operating in conjunction with any other antenna or transmitter. The user is cautioned that changes or modifications made to the equipment without the approval of the manufacturer could void the user's authority to operate this equipment.

Table of Contents

PRODUCT CONCEPT	2	Configuring the System Components	7
Wireless Sensor System Components	3	A. Configure System ID	7
Network Manager (NM)	3	Entering the System ID in the WP.	7
Transceiver/Router (RTR)	3	Entering the System ID in the WP.	8
Sensor (SNR)	3	Setting the System ID on a Wireless SNR, RTR, or NM	8
Wireless Programmer (WP)	3	B. Configuring RTR Network Number	8
Wireless Address Coding	3	Getting the System Component Configuration	9
RF Mapping (Survey)	4	DETECT RSSI Mode	11
Wireless Programmer (WP) Emulation and Antennas	5	SNIFF Mode	12
Setting the System ID	5	CAPTURE Data	13
Emulating a Network Manager (NM)	5	Clear CAPTURE Data	13
Emulating a Transceiver/Router (RTR)	6	TROUBLESHOOT	14
Emulating a Sensor (SNR)	6		

PRODUCT CONCEPT

The Heat-Timer Wireless Network Sensor System is designed to be utilized in a variety of large buildings, garden apartments, and in retrofit applications, giving both the accuracy and flexibility required to heat those buildings. The Heat-Timer Wireless Network Sensor System is designed to ease the installation of space sensors in buildings where it would be difficult or cost prohibitive utilizing other means. Thus, allowing Heat-Timer Platinum controls with communication the access to the wireless sensor data. The values read from the wireless system is used by the Platinum controls to fine-tune its operation. Furthermore, the Platinum controls can be configured to log this information using the proper communication package.

The primary integral components of the system are: the Network Manager (NM), the Transceivers/Routers (RTR), the Wireless Sensors (SNR), and finally, the Wireless Programmer (WP). The SNRs communicate their information to a nearby RTR or NM. The RTRs trickle down the information down either to another RTR or to the NM. The WP is a tool that is used to map, configure, diagnose, and troubleshoot the Heat-Timer Wireless Network System.

The NM is connected to the Heat-Timer Platinum control using a cabled RS485 connection. The SNRs communicate their information to the RTRs and the NM. The RTRs will pass down the information to other RTRs until finally all the information is passed down to the NM. The NM will transmit the data using RS485 connection to the Platinum control. The control will process the data and pass it to the Internet to Heat-Timer servers or thru Visual Gold Plus to a computer. An Internet Control Management System (ICMS) client can access this information by logging to their web account.

Security

Each Wireless Sensor Network System will have a unique ID that prevents it from getting access to other wireless systems as well as prevent other systems from accessing it. That means, a NM, RTR, or SNR can only listen to and transmit to another component on the same unique network. Each of the wireless system components must be configured to the specific network for it to communicate.

Improved Penetration and Extended Range.

The HT-Wireless Network Sensor System utilizes the 900MHz frequency range for better penetration. The Frequency Hopping Spread Spectrum has been used to improve performance and range. This allows the system to be installed not just in high-rise buildings, but also in garden apartments, campus type environment, etc. For applications where long ranges between components is required, the utilization of RTRs with External High Gain Antennas will help reduce the number of intermediate RTRs

WIRELESS SENSOR SYSTEM COMPONENTS

Network Manager (NM)

The NM is the primary component in the Heat-Timer Wireless Sensor System. It collects the data from all the sensors and routers and passes it on to the Heat-Timer Platinum control. Each Heat-Timer wireless network has only one NM. However, one NM can be connected to multiple Heat-Timer Platinum controls. The NM can listen to RTRs and SNRs. It is connected directly to the Heat-Timer Platinum control using a RS485 connection to the RI board on the back of the control. The NM has an External High Gain Antenna with an extended cable that can be mounted remotely. The NM can communicate to two upstream RTRs. The NM is powered using a 5 to 8 VAC transformer. The WP can provide power to the NM when connected to it using the RS485 phone cable for surveying programming, and troubleshooting.

Transceiver/Router (RTR)

When SNR locations are not within reception range of the NM, the RTR can act as a range extender. Multiple RTRs can pass on the information from the SNRs to the NM. A Single RTR can communicate to many sensors. Two RTRs with an External High Gain Antennas can be used to extended the transmission range over large distances. A RTR can communicate to two upstream RTRs. It is powered using a 5 to 8 VAC transformer. The WP can provide power to the RTR when connected to it using the RS485 phone cable for surveying programming, and troubleshooting.

Sensor (SNR)

The SNR measures the space temperature and passes it in addition to its battery status and other information to a nearby RTR or NM. It is powered by two AA batteries (different SNRs require different AA battery voltage).

Wireless Programmer (WP)

The WP is the tool used to map/survey, configure, emulate, power, diagnose, and troubleshoot the Heat-Timer Wireless Sensor System. In the survey process, it emulates each of the wireless components. Later, it is needed to set the Wireless Network parameters and configure each of the components based on the initial survey. It can be connected to each of the Heat-Timer Wireless Network System using a RS485. When connected to a NM or RTR, it will provide power to that component. Moreover, it is used as a diagnostic tool, by listening and analyzing system data. The WP is powered using a rechargeable Ni-Cd internal battery. The WP comes with an external charger.

WIRELESS ADDRESS CODING

The Heat-Timer Wireless Network Sensor System is designed for extension and growth. A single wireless network can have a large number of RTRs that communicate to a larger number of SNRs. Each NM or RTR (Parent) can communicate directly to two upstream RTRs (Children). The diagram is a sample RTR addressing structure.

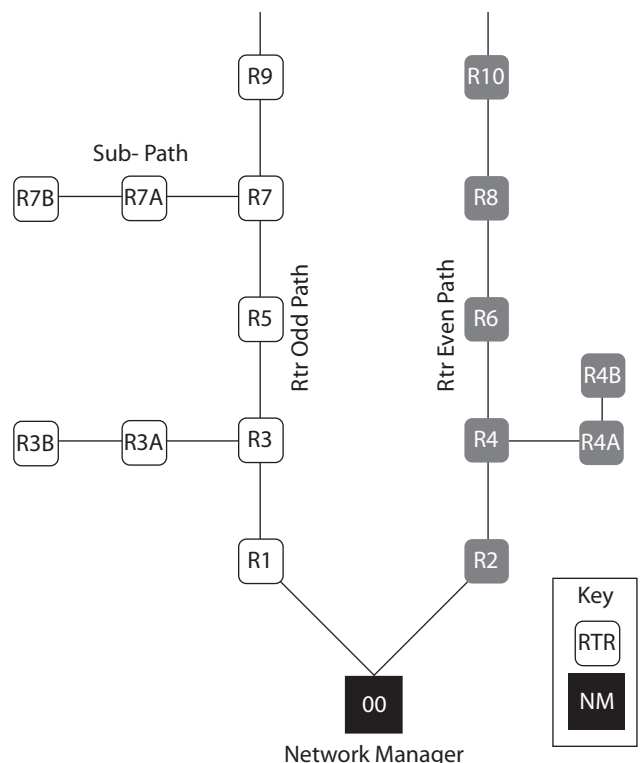

INSTALLATION

Prior to purchasing the wireless components, an RF Mapping survey must be done. After the survey, the NM, RTRs, and SNRs can be programmed and installed at the locations assigned using the survey followed by connecting the NM to the Platinum control. Finally, configure each of the wireless components (SNRs) using the communication interface (Visual Gold Plus or the Internet) for the Platinum control. Remember that NM and RTRs can only be configured on the Internet. That is after the physical installation of the wireless components, log on to the Internet or Visual Gold Plus to the Heat-Timer Platinum control to configure the individual wireless components to work with the Heat-Timer control.

RF MAPPING (SURVEY)

The goal is to assign the wireless components to the locations which best meets building, user, power source, and best transmission criteria. The survey involves the use of two WPs. Each of the WPs will be set to emulate a different component of the Heat-Timer Wireless Network System. Then, test communication between the different components. You must set both WPs to the same System ID#.

(A Survey) Assign the NM & First RTR locations:

- Initially, setup the first WP1 to emulate a NM and the second to emulate a RTR. Since the NM will have a high gain antenna, connect a high gain antenna (Long Antenna) to the WP1 (emulating the NM). Place the first WP1 (emulating the NM) where it can be connected to the Heat-Timer Platinum control, normally within the boiler room. Make sure that a power source is available to power the NM.
- Place the second WP2 (emulating the first RTR) in one of the floors above where it can communicate with the WP1. Again, make sure that the locations selected have a power source where the RTR transformer can be connected to.
- Test the signal strength between the two WPs. The signal strength reading (RSSI) should be above 650 for a reliable connection. Upon having good communication *MARK* the two locations of the WPs. Mark the WP1 (emulating the NM) with P1 (Position 1)=NM and WP2 (emulating RTR) with P2 (Position 2)=RTR1. If a good signal strength cannot be achieved try replacing the WP2 Low-Gain antenna (Short Antenna) with a High-Gain antenna (Long Antenna). If that was successful, you'll need to assign an External RTR with the High-gain antenna to that location.

(B Survey) Assign the Second RTR location:

- Now, move the WP1 (NM) from the boiler to the location of the WP2 (RTR)=P2. If in the (A Survey) WP2 had a low gain antenna, make sure that in the (B Survey) WP1 has a low gain antenna as well.
- Then move the second WP2 (RTR) to emulate the second upstream router and repeat the process. Mark the WP2 (emulating the second RTR) with P3=RTR3. For the wireless network to function, it requires the presence of a NM with the same System ID as the wireless network. Thus, keeping one of the WPs set as a NM will maintain the accessibility of the wireless network.

Building Cutaway

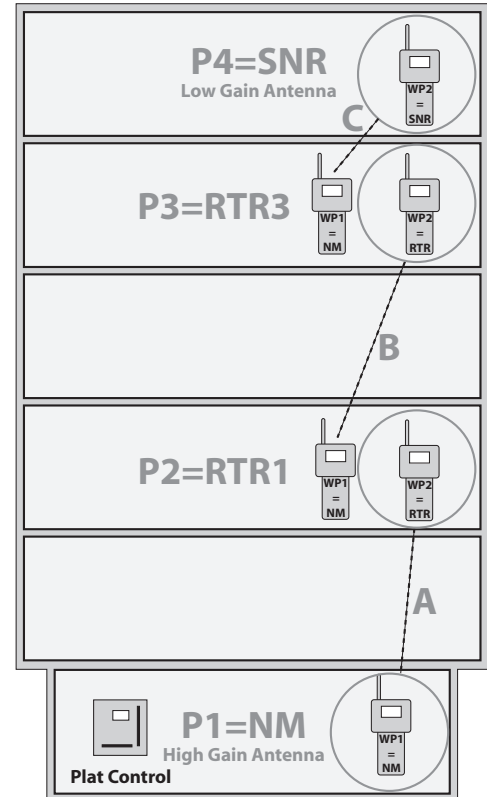

▲ IMPORTANT

- When the WP is emulating a NM or an External RTR, the High Gain Antenna (Long Antenna) must be used for accurate reception strength.

⚠ IMPORTANT

- A NM or a RTR (Parent) can communicate to ONLY TWO upstream RTRs (Children). It is important for the installer to map the location based on this concept.
- When placing multiple wireless components, make sure there is at least six feet of spacing between any two antennas or an antenna and a high voltage power line to reduce frequency noise.



(C Survey) Assign the SNR location:

- Now, move the WP1 (NM) from the P2 location to the WP2 (RTR)=P3. If in the (B Survey) WP2 had a low gain antenna, make sure that in the (C Survey) WP1 has a low gain antenna as well.
- Then, program the second WP2 to emulate a SNR. Make sure that WP2 (SNR) has a low gain antenna. Place the WP2 on an inside wall five to six feet off the floor in the room that represents the actual space temperature away from windows, heaters, vents, and shelves or objects that may impeded the air flow. It should not be mounted in bathrooms, kitchens, or closets.

WIRELESS PROGRAMMER (WP) EMULATION AND ANTENNAS

To perform a building mapping/survey, the WP must be set to emulate the different Heat-Timer Wireless Network components. The WP comes with two different antennas a short (low gain) and a long (high gain). The short antenna (low gain) should be connected to the WP when it is emulating a SNR or a standard RTR with an internal antenna. The long antenna (high gain) should be used when the WP is emulating a NM or a RTR with an External High Gain Antenna (long range applications). That will give the surveyor the capability of testing transmission and reception signal strength as well as assign locations to the different wireless components. To set the WP to emulate each component, follow the component emulation process. Before starting the process, The System ID must be set.

Setting the System ID

- Make sure that the WP is fully charged.
- Power the WP on. That should turn the LED to Green.
- Select **WP.Setup Mode** from the Main menu by pressing the (Enter / ) button. Then, type a System ID or press the (Down / ) button to select a random Id. To accept the new System ID press the (Enter / ) button. Then, press the **F** button to load it into the WP.
- This will be followed by the Emulation Mode.
- Remember to record the System ID to help you in setting up the next WP to the same System ID.

```
-WP.SETUP mode
SYSTEM ID# C9E5
[UP] delete
[DOWN] pick
```

```
*CONFIG. MODE[9]
WP.Sys Id# C9E5
[F] to load
```

```
-WP.Setup mode
> Emulate RTR
  Emulate SNR
  Emulate NM
```

```
-WP.Setup mode
EMULATE NM
[F] to load
```

```
-WP.Setup mode
Setup complete
[Mode] to exit
```

⚠ WARNING

DO NOT use 0000 as a System ID to avoid errors in operation. The Heat-Timer Wireless Network components can communicate only if they have the same System ID.

Emulating a Network Manager (NM)

- After setting the System ID on the WP, the Emulation menu will display.
- Select **EMULATE NM** and Press the  followed by the **F** to proceed with the NM Emulation. An **ACK** (Acknowledge) will appear on the third line of the display acknowledging the acceptance by the WP.
- Press the **Mode** to enter the **SURVEY MODE**, which appears on the top of the display. The second display line will read **NET MANAGER**.

Exit NM Emulation:

- To exit this mode, press the **Mode** to go back to the System ID# Setup.

```
-WP.SETUP mode
SYSTEM ID# C9E5
[UP] delete
[DOWN] Pick
```

Mode

⚠ IMPORTANT

To exit the NM Survey Mode the user **MUST** Select to Emulate a RTR or a SNR first.

```
SURVEY MODE
NET MANAGER
```

Mode

Emulating a Transceiver/Router (RTR)

- After setting the System ID on the WP, the Emulation menu will display.
- Select **EMULATE RTR** and Press the **↵**. The option for the transmission power will follow.
- A RTR will default to 100mw transmission power. Do not change this value. Press the **F** to accept transmission power and proceed to the Sniff/Detect RSSI menu.
- Select **DETECT RSSI** using the **↵** button followed by the **F** to accept.
- Press the **Mode** to go to the main menu.
- Select **Auto Mode** using the **↓** or **↑** buttons. Then press the **↵** button to accept. Within a few seconds, data should start to show on the display.
- The Numbers below the **MASTER** and **UPROG** represents the signal strength received by each of the components from the other component. That is, the number below **MASTER** represents how well the **MASTER** was received by the **UPROG**.
- The fourth line data contains **R01** which represents the master's ID. A **00** represents the NM. Any ID that starts with the **R** represents a RTR.
- The **NEW 01A** represents the next RTR ID upstream available.

```
-WP.Setup mode
EMULATE RTR
>100mw 200mw
[F] to load
```

Accept 100mw F

```
-WP.Setup mode
SNIFF
> DETECT RSSI
```

Accept Detect RSSI ↵

```
-WP.Setup mode
DETECT RSSI
[F] to load
```

Enter the Detect RSSI F

```
Config devices
Get device data
WP.Setup Mode
>Auto Mode
```

Enter Auto Mode ↵

```
AUTO MODE
MASTER      UPROG
65          62
R01  NEW 01A
```

Exit RTR Emulation:

- To exit this mode, press the **Mode**. The **Clear capture data** option will show.
- Pressing the **Mode** again will direct you to the **AUTO MENU**.

```
*AUTO MODE
Clear capture data
Yes >No
```

Mode

```
AUTO MENU [1]
Auto Mode
Capture
RTR TABLE
SNR TABLE
>Exit Auto Mode
```

Mode

```
Config devices
Get device data
WP.Setup Mode
>Auto Mode
```

↵

Emulating a Sensor (SNR)

- After setting the System ID on the WP, the Emulation menu will display.
- Select **EMULATE SNR** and Press the **↵**.
- Select from the Detect RSSI/Sniff menu **DETECT RSSI** using the **↵** button followed by the **F** to accept.
- Press the **Mode** to go to the main menu.
- Select **Auto Mode** using the **↓** or **↑** buttons. Then, press the **↵** button to accept. Within a few seconds, data should start to display.

```
-WP.Setup mode
EMULATE SNR
[F] to load
```

Accept Emulate SNR F

```
-WP.Setup mode
SNIFF
> DETECT RSSI
```

- The Numbers below the MASTER and UPROG represents the signal strength received of each of the components from the other component. That is, the number below MASTER represents how strong the MASTER was heard by the UPROG.
- The fourth line data contains 00 which represents the master's ID. A 00 represents the NM. Any ID that starts with the R represents a RTR.

Exit SNR Emulation:

- To exit this mode, press the **Mode**. The Clear capture data option will show.
- Pressing the **Mode** again will direct you to the AUTO MENU.
- Select Exit Auto Mode to go back to the main menu.

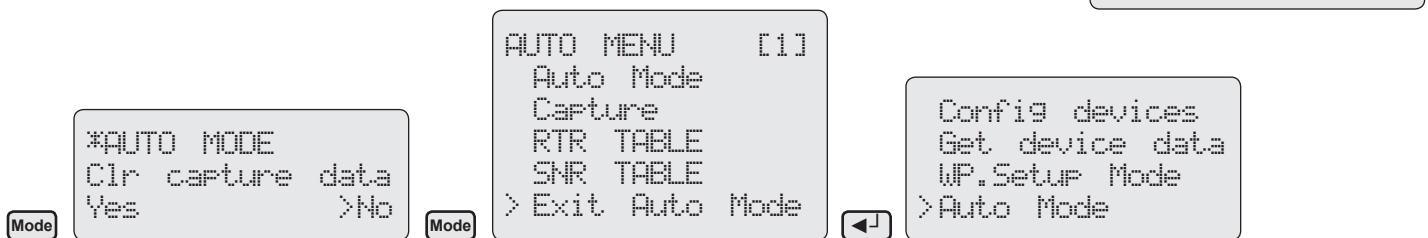

CONFIGURING THE SYSTEM COMPONENTS

For the Heat-Timer Wireless Network Sensor System to function, a NM with a System ID must be activated. The WP is the only way any of the wireless components can be configured. For a new installation, start by configuring the NM. Then, configure the RTRs followed by the SNRs.

A. Configure System ID

Each wireless network should have a unique System ID. The System ID enables all wireless components with that ID to communicate to each other. The WP is the only tool used to configure all system components and their parameters. Connect the WP using the phone cable to the wireless component to be configured with the System ID. The WP will power the NM or RTR if no power source was connected to them. However, a SNR must have its batteries connected and operational and the SNR in Install mode (by pressing and holding the SNR Install button). Then, configure the WP with the System ID to be used on the Heat-Timer Wireless Network Sensor System.

Entering the System ID in the WP

- Make sure that the WP is fully charged.
- Power the WP on. That should turn the LED to Green.
- Select WP.Setup Mode from the Main menu by pressing the (Enter / **↵**) button. Then, type a System ID or press the (Down / **▼**) button to select a random Id. To accept the new System ID press the (Enter / **↵**) button. Then, press the **F** button to load it into the WP.
- This will be followed by the Emulation Mode menu.

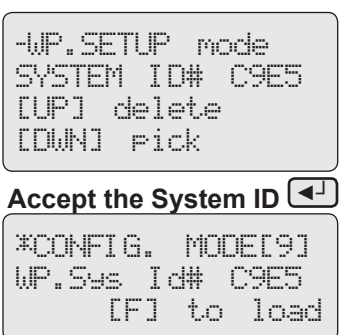
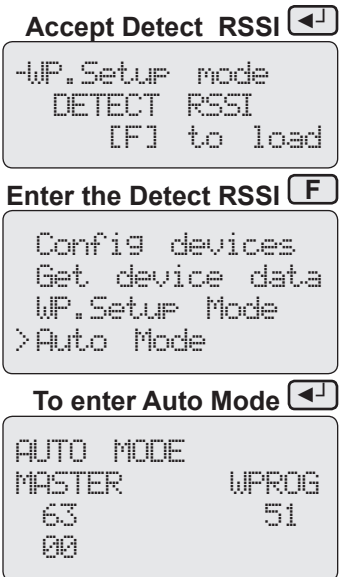

⚠ WARNING

DO NOT use 0000 as a System ID to avoid errors in operation. The Heat-Timer Wireless Network components can communicate only if they have the same System ID.

Setting the System ID on a Wireless SNR, RTR, or NM

- After setting the WP to the System ID, you'll need to configure the wireless components; SNR, RTR, and NM, with the System ID.
- When in the Emulation menu (WP.Setup Mode) press the **[Mode]** button to return to the main menu.
- Select **Config devices** from the Main menu by pressing the (Enter / **[↵]**) button. Then, select **System Id** from the list by pressing the (Enter / **[↵]**) button. This will display the System ID configured into the WP.
- Make sure that the phone cable is connected to the WP and the wireless component to be programmed.
- Press the **[F]** button to load the System ID into the wireless component.
- This will display **ACK** on the third line of the display acknowledging the wireless component acceptance of the new System ID.

⚠ IMPORTANT

After configuring a SNR with the System ID for the first time, the SNR will go to Sleep/Normal Mode until the next wake up interval. To bring back the SNR to the Install mode, the user must press and hold down the SNR button for three seconds or until the SNR PCB LED light starts blinking.

Load the System ID **[F]**

```
-WP.Setup mode
> Emulate RTR
  Emulate SNR
  Emulate NM
```

Exit to Main Menu **[Mode]**

```
>Config devices
  Get device data
  WP.Setup Mode
  Auto Mode
```

Accept Config Devices **[↵]**

```
*CONFIG. MODEL91
>System Id
  Reset Sensor
  PUER dwn SNR
```

Select System ID **[↵]**

```
*CONFIG. MODEL91
WP.Sys Id# C9E5
[F] to load
```

To load the System ID **[F]****B. Configuring RTR Network Number**

For the RTRs to function in a wireless system, each must be assigned a Network Number. The Network Number determines the path the information uses to pass on from one RTR to the next all the way down to the NM. The main concept is that the NM can communicate upstream directly to a maximum of two RTRs. Each of the two RTRs will represent a main path for the data to travel through. The first main path RTRs will have odd Network Numbers. The first RTR (R01) on the first main path will be set to communicate to the NM (has a fixed Network Number of 00). The second RTR up the same path will be R03 and so on. The second path primary RTR will have a Network Number of R02. The second RTR up the same path will be R04.

- Make sure that the WP is fully charged.
- Power the WP on. That should turn the LED to Green.
- Select **Configure devices** from the Main menu by pressing the (Enter / **[↵]**) button.
- Then, scroll in the menu using the (Down / **[▼]**) or (Up / **[▲]**) buttons to select **RTR address** menu option.
- Use the (Down / **[▼]**) or (Up / **[▲]**) buttons to change the RTR Network Number. Make sure the RTR Network number is not repeated within the same wireless network.
- Use the **[0]**, **[A]**, **[B]**, **[C]**, **[D]**, or **[E]** buttons configure the Suffix of the RTR Network Number. The Suffix will determine the RTR sub-path.

```
>Config devices
  Get device data
  WP.Setup Mode
  Auto Mode
```

Accept Config Devices **[↵]
Scroll to RTR Address **[▲]****

or
[▼]

```
*CONFIG. MODEL41
Wake up Period
RF out
>RTR address
```

- Press the **F** button to load the RTR Network Number.
- This will display **ACK** on the third line of the display acknowledging the RTR acceptance of the new Network Number.

To select RTR address 

```
*CONFIG. MODE[4]
  RTR NET#01 0
  USE UP & dwn
  FOR SUFFIX[0AB]
```

GETTING THE SYSTEM COMPONENT CONFIGURATION

To find out the wireless component configuration parameters, the WP must be in the **Get device data** menu. This menu will allow the WP to display the wireless component specific parameter settings. The wireless component must be connected to the WP using the phone cable supplied with the WP. The NM and RTRs can temporarily be powered by the WP when the cable is connected. However, the SNR must have its batteries installed and be in the Install Mode (by holding the SNR button for three seconds until PCB LED starts blinking continuously).

After selecting each setting, press the **F**. This will display the setting value for approximately two seconds.

```
Config devices
>Get device data
  UP.Setup Mode
  Auto Mode
```

```
*GET MODE [11]
>Get RSSI
  Get Volt
  Get Version
  Get Type
  Get H.Beat
  Get RF out
  Get NET ADD#
  Get System Id
  Get Module Id
```

- | | |
|------------------------|--|
| RSSI (Read Only): | Represents the reception power. It indicates the strength the parent component can hear the current component. |
| Volt (Read Only): | It indicates the Voltage status of the SNR batteries. If the Voltage is less than 3.0, replace the batteries. |
| Version (Read Only): | Will indicate the Hardware and Software versions of the current wireless component. Useful when contacting factory. |
| Type (Read Only): | When selected will display if the wireless component was a NM, RTR, or SNR. |
| Heart Beat: | For the SNR, it is the interval at which the SNR is programmed to wake up and start transmitting its data. For the NM and RTRs, it is the interval at which they will transmit their status (RTR Network Number, RSSI, Module ID, and RF Out) to their parent. |
| RF Out: | Each of the wireless components is pre-configured to transmit at a specified appropriate RF strength. The NM and RTRs are factory set to 100mw. While the SNR is set to 25mw. DO NOT change these values. |
| Net Address #: | This is the Network Number of wireless component displayed in HEX format. <i>See Network Address Number Translation Table.</i> SNR Network Numbers indicate the RTR or NM the SNR is communicating to. |
| System ID: | Applies to all wireless components; NM, RTR, SNR. Only components with the same System ID can communicate to each other. |
| Module ID (Read Only): | Is the unique ID of each component that is used to identify and configure it on the Platinum Remote communication package, or the Internet. |

NETWORK ADDRESS NUMBER TRANSLATION

MAIN PATH RTR	NETWORK ADD#
NM	0180-0000
RTR ODD PATH	
Router 1	0280-0000
Router 3	0380-0000
Router 5	0480-0000
Router 7	0580-0000
Router 9	0680-0000
Router 11	0780-0000
Router 13	0880-0000
Router 15	0980-0000
Router 17	0A80-0000
Router 19	0B80-0000
RTR EVEN PATH	
Router 2	02C0-0000
Router 4	03C0-0000
Router 6	04C0-0000
Router 8	05C0-0000
Router 10	06C0-0000
Router 12	07C0-0000
Router 14	08C0-0000
Router 16	09C0-0000
Router 18	0AC0-0000
Router 20	0BC0-0000

SUB-PATH RTR	NETWORK ADD#
SUB-PATH A	
Router 1A	03A0-0000
Router 3A	0490-0000
Router 5A	0588-0000
Router 7A	0684-0000
Router 9A	0782-0000
Router 11A	0881-0000
Router 13A	0980-8000
Router 15A	0A80-4000
Router 17A	0B80-2000
Router 19A	0C80-1000
SUB-PATH B	
Router 2A	03E4-0000
Router 4A	04D0-0000
Router 6A	05C8-0000
Router 8A	06C4-0000
Router 10A	07C2-0000
Router 12A	08C3-0000
Router 14A	09C0-8000
Router 16A	0AC0-4000
Router 18A	0BC0-2000
Router 20A	0CC0-1000

SUB-PATH RTR	NETWORK ADD#
SUB-PATH B	
Router 1B	04A0-0000
Router 3B	0590-0000
Router 5B	0688-0000
Router 7B	0784-0000
Router 9B	0882-0000
Router 11B	0981-0000
Router 13B	0A80-8000
Router 15B	0B80-4000
Router 17B	0C80-2000
Router 19B	0D80-1000
SUB-PATH C	
Router 2B	04E4-0000
Router 4B	05D0-0000
Router 6B	06C8-0000
Router 8B	07C4-0000
Router 10B	08C2-0000
Router 12B	09C3-0000
Router 14B	0AC0-8000
Router 16B	0BC0-4000
Router 18B	0CC0-2000
Router 20B	0DC0-1000

DETECT RSSI Mode

Detecting RSSI is available only when the WP is emulating a RTR or a SNR. It allows the WP to show the loudest wireless transmitters within a specific Network (have the same System ID) within an area at any point in time. Thus, it will not show all wireless transmitters. It is primarily used in mapping a new wireless network, adding wireless components to an existing one, or in troubleshooting a wireless component transmission or reception.

- Power the WP on. That should turn the LED to Green.
- Select `WP.Setup Mode` from the Main menu by pressing the (Enter / `<J`) button. Then, type the System ID of the existing wireless network. To accept the new System ID press the (Enter / `<J`) button. Then, press the `F` button to load it into the WP.
- Select `EMULATE RTR` or `EMULATE SNR` from the Emulation menu and Press the `<J`. The option for the transmission power will follow.
- If emulating a RTR, the transmission power screen will display. Select 100mw transmission power. Press the `F` to accept transmission power.
- Select `DETECT RSSI` from the Sniff/Detect RSSI menu using the `<J` button followed by the `F` to accept.
- Press the `Mode` to go back to the main menu.
- Select `Auto Mode` then press the `<J` button to accept. Within a few seconds, data should start to display.
- The Numbers below the `MASTER` and `WPROG` represents the signal strength received of each of the components from the other component. That is, the number below `MASTER` represents the strength the `MASTER` signal was received by the `WPROG`.
- The fourth line data contains `R01` which represents the master's ID. A `00` represents the NM. Any ID that starts with the `R` represents a RTR.

Exit Emulation:

- To exit this mode, press the `Mode`. The `Clear capture data` option will show.
- Pressing the `Mode` again will direct you to the `AUTO MENU`.
- Select `Exit Auto Mode` to go back to the main menu.

```
-WP.Setup mode
SYSTEM ID# C9E5
[UP] delete
[DOWN] Pick
```

Accept the System ID `<J`

```
*CONFIG. MODEL91
WP.Sys Id# C9E5
[F] to load
```

Load the System ID `F`

```
-WP.Setup mode
> Emulate RTR
Emulate SNR
Emulate NM
```

Accept Emulation `<J`

```
-WP.Setup mode
EMULATE RTR
>100mw 200mw
[F] to load
```

Accept 100mw `F`

```
-WP.Setup mode
SNIFF
> DETECT RSSI
```

Accept Detect RSSI `<J`

```
-WP.Setup mode
DETECT RSSI
[F] to load
```

Enter the Detect RSSI `F`

```
Config devices
Get device data
WP.Setup Mode
>Auto Mode
```

Enter Auto Mode `<J`

```
AUTO MODE
MASTER      WPROG
65          62
R01 NEW 01A
```

```
*AUTO MODE
Clr capture data
Yes >No
```

`Mode`

```
AUTO MENU [1]
Auto Mode
Capture
RTR TABLE
SNR TABLE
>Exit Auto Mode
```

`Mode`

```
Config devices
Get device data
WP.Setup Mode
>Auto Mode
```

`<J`

SNIFF Mode

The Sniff Mode allows the WP to listen to all surrounding wireless components with the same System ID regardless of their reception level (RSSI). The user will need to program the WP to Emulate a RTR or a SNR. It is used to detect if a wireless component is functioning within a specified area.

- Make sure to Clear Captured Data prior to starting the Sniff Mode to start with cleared tables. *See Clear Capture Data.*
- Select **WP.Setup Mode** from the Main menu by pressing the (Enter / **↵**) button. Then, type a System ID or press the (Down / **▼**) button to select a random Id. To accept the new System ID press the (Enter / **↵**) button. Then, press the **F** button to load it into the WP.
- This will be followed by the Emulation Mode.
- After setting the System ID on the WP, the Emulation menu will display.
- Select **EMULATE RTR** or **EMULATE SNR** and Press the **↵**.
- If emulating a RTR, the transmission power screen will display. Select 100mw transmission power. Press the **F** to accept transmission power.
- Then, select **SNIFF** using the **↵** button followed by the **F** to accept.
- Press the **Mode** to go to the main menu.
- Select **Auto Mode** then press the **↵** button to accept. Within a few seconds, data should start to show on the display.

SNIFF Data Views

```
AUTO MODE
B 04800000 05
```

- The **B** represents a RTR beacon. The rest of the number indicates the HEX Network Address Number. The Last **05** translates the HEX into the RTR Network Number.

```
AUTO MODE
BR
#0000046E
```

- The **BR** represents a beacon request which is normally initiated by a SNR. The rest of the data **0000046E** represents the SNR Module ID.

```
AUTO MODE
S 0000046E
15M 25mw
```

- The **S** represents the data was received from a SNR. An **R** instead of the **S** represents that the SNR data was received through a RTR. The following **0000046E** represents the SNR Module ID. The **15M** represents the Wake up period of the SNR which is programmed to 15 minutes. The **25mw** is the transmission power setting which is programmed to the default 25 milliwatts.

```
-WP.Setup mode
SYSTEM ID# C9E5
[UP] delete
[DOWN] pick
```

Accept the System ID **↵**

```
*CONFIG. MODEL9]
WP.Sys Id# C9E5
[F] to load
```

Load the System ID **F**

```
-WP.Setup mode
> Emulate RTR
  Emulate SNR
  Emulate NM
```

Accept Emulation **↵**

```
-WP.Setup mode
EMULATE RTR
>100mw 200mw
[F] to load
```

Accept 100mw **F**

```
-WP.Setup mode
> SNIFF
  DETECT RSSI
```

Accept SNIFF Mode **↵**

```
-WP.Setup mode
SNIFF
[F] to load
```

Enter the SNIFF Mode **F**

Exit to Main Menu **Mode**

```
Config devices
Get device data
WP.Setup Mode
>Auto Mode
```

Enter Auto Mode **↵**

CAPTURE Data

The Capture displays the data collected during the Sniff Mode. It is helpful since the Sniff Mode displays the data for a short period of time. This data can then be taken back to the office where it can be analyzed. To read the Capture data collected in Sniff Mode.

- Go to the Auto Mode from the Main menu.
- Press the **Mode** button twice to reach the Auto Menu.
- Select **Capture** from the menu.
- Scroll using the (Down / **▼**) or (Up / **▲**) buttons to view all the SNR, RTR, and NM data collected. *See Sniff Data Views.*

```
AUTO MODE
R 0000046E
15M 25nw
```

Mode

```
*AUTO MODE
Clr capture data
Yes >No
```

Mode

```
AUTO MENU [1]
Auto Mode
> Capture
RTR TABLE
SNR TABLE
Exit Auto Mode
```

Clear CAPTURE Data

It is important to Clear Capture Data prior to going into Sniff Mode to start with empty tables.

- Go to the Auto Mode from the Main menu.
- Press the **Mode** button once to reach the Clear Capture Data menu.
- Select **Yes** from the menu and then press the (Enter / **↵**) to accept. This will clear the old data and take you back to the Auto Mode.

```
AUTO MODE
R 0000046E
15M 25nw
```

To enter Clr Capture **Mode**

```
*AUTO MODE
Clr capture data
>Yes No
```

Press Enter to Accept **↵**

TROUBLESHOOT

SNR Does Not Communicate

- If a specific SNR is not communicating, it could be due to low battery power or dead batteries, the SNR have the wrong System ID, or that the RTR or NM cannot hear the SNR.
- To Test for low or dead batteries, you can view the Internet status on the SNR. For Visual Gold Plus communication packages users, that information is not available remotely. Thus, connecting the WP to the SNR must be done.
- Otherwise, if you have no access to the SNR, place the WP within the SNR transmission range. Configure the WP to emulate a RTR in the Sniff Mode for 20 minutes. *See Sniff mode instructions.* Then review the Captured Data and try to locate the SNR using the SNR Module ID. *See Capture Data instructions.*
- If you have access to the SNR, connect the WP to the SNR and use the `Get device data` menu and select `Get Volt`. Remember that the SNR must be in the Install Mode (by holding down the SNR button for a few seconds or until the PCB LED blinks continuously). If the Voltage is less than 3.0, replace the batteries.

SNR Communicates Intermittently

- If a specific SNR occasionally loses its communication, it could be due to the location of the SNR relation to the RTR or NM location. Otherwise, it could be due to a problem with the RTR communication.
- To find out if the SNR location is appropriate, configure the WP to `Emulate RTR` and select `Detect RSSI Mode`. Disconnect the power to the RTR the SNR was designed to communicate to and place the WP in its location. By default SNRs are designed to communicate every 15 minutes. Watch for the SNR ID to show and both RSSI values. If values fluctuate around or below 50, you'll need to relocate the SNR to a better reception area. Otherwise, if the RSSI values were good, then the problem is not with the SNR but with the RTR communicating downstream. *See RTR Communicates Intermittently.*

RTR Does Not Communicate

- If a group of nearby SNRs does not communicate, most likely, it is due to a RTR that has no communication downstream (to parent).
- Make sure that the RTR is powered and some of its LEDs are blinking every few seconds. That indicates that the RTR is powered.
- Put the WP in `Get System Id` and connect it to the RTR and press the **F** to make sure that the RTR has the same System ID as the rest of the wireless network.
- Put the WP in `Get NET ADDR#` to make sure that the RTR is programmed with the correct Network Address. Each RTR must have a Network Address that is unique and sequential as per the Wireless Address Coding Chart. Also, *see Configuring RTR Network Number.*
- To see if the RTR reception is sufficient, connect the WP to it and put the WP in `Get RSSI`. The RSSI must be above 60. However for constant reliable connection, a much higher value should be achieved.

RTR Communicates Intermittently

- If a RTR communicates intermittently, it is either due to its location, thus, having a low RSSI value (transmission/reception). Otherwise, it is due to its parent RTR having a low RSSI value.
- To see if the RTR reception is sufficient, connect the WP to it and put the WP in `Get RSSI`. The RSSI must be above 60. However, for constant reliable connection, a much higher value should be achieved.

Wireless Programmer Specifications:

Power Input:	9.6 VDC (rechargeable Ni-Cd battery)
Frequency:	RF 900mHz FHSS
Signal Strength:	25mw to 250mw
Antennas:	External High Gain Antenna / Long (to emulate External RTRs and NM) Internal Low Gain Antenna / Short (to emulate Internal RTRs and SNRs)
Buttons:	20 button keypad
Switch:	1 Power Switch
LED:	One dual-color LED (Green=ON, Red=Charging)
Display:	4 Lines 16 character per line.
Programming Interface:	RS485
Dimensions:	.5" x 9" x 1- ⁵ / ₈ "