

Installation and Operation Manual

Stack Sensor

Stack Sensor for Stand Alone or Internet Installation

Stack Sensor with Network Interface

for Platinum Control Internet
Communication

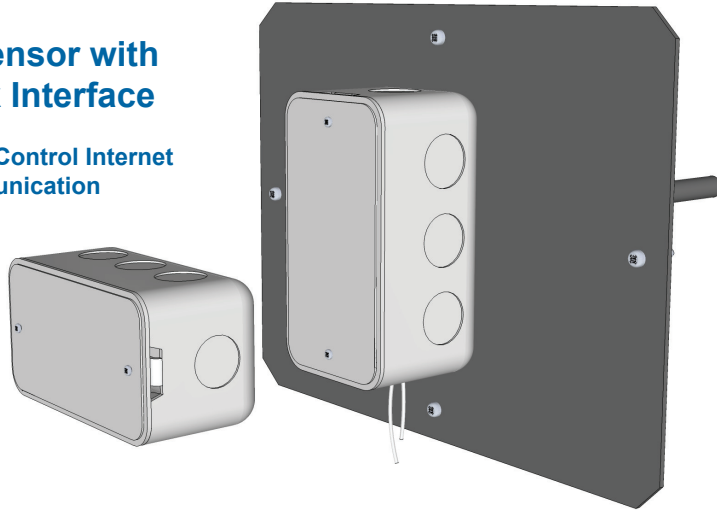

Stack Sensor with SPC-Elite

for Visual or Audio Alarming

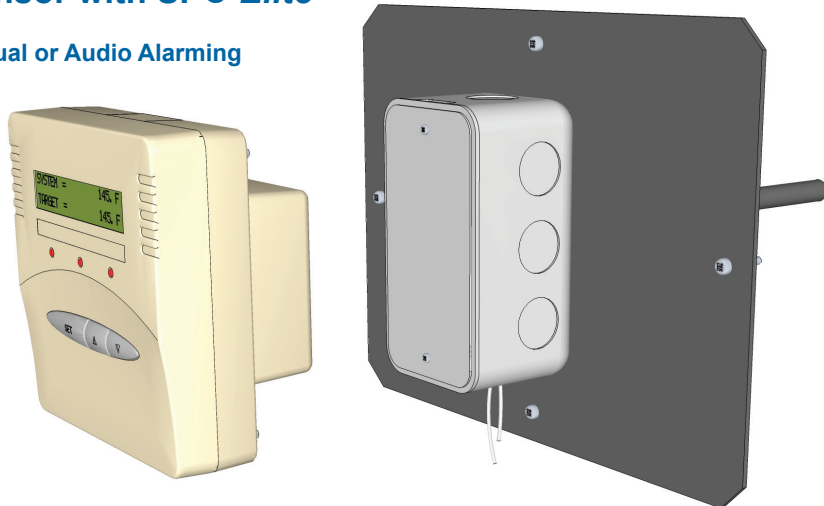

⚠ WARNING

This Heat-Timer control is strictly an operating control; it should never be used as a primary limit or safety control. All equipment must have its own certified limit and safety controls required by local codes. The installer must verify proper operation and correct any safety problems prior to the installation of this Heat-Timer control.

Overview

Knowing the stack temperature can help improve boiler efficiency. The Heat-Timer Stack Sensor is designed to connect to the SPC-Elite to facilitate local monitoring and alarm triggering whenever the stack temperature rises to an adjustable set point. For remote Internet monitoring, it can be connected to the Network Interface that is connected to Platinum Internet ready heating control (RINet). In this case, the alarms are sent as a cell phone text message or an E-mail.

A high stack temperature indicates inefficient boiler operation; i.e. sooted boiler. Monitoring can lead to prompt maintenance, increasing performance, and preventing boiler damage.

Item List

Two types of Stack Sensor Kits are available. See each kit's item list and its alarming capability.

Stack Sensor with SPC-Elite (Order both HT# 904045-00 and 929150-UA)

- SPC-Elite (929150-UA)
- Stack Sensor (904045-00)

This SPC-Elite output can then be connected to a Vis-U-Alarm (925011-00), an alarm bell, or an EMS input.

Stack Sensor with Interface For Internet Communication (HT# 904048-00)

- Stack Network Interface (904047-00)
- Stack Sensor (904045-00)

The Stack Network Interface can be connected to an Internet ready Platinum control. A Network Power Supply is required (NPS 926670-00). The sensor and alarms must be configured on the web using the ICMS (<http://www.htcontrols.com>). Alarms will be in the form of viewable web alarm, E-mail, or text message to a cellular phone.

Installation Steps

Stack Sensor with SPC-Elite

- Install the Stack Sensor
- Install the SPC-Elite
- Wire the Stack Sensor and the Alarm to the SPC-Elite
- Set the SPC-Elite's Sensor Type, Set Point, and Differential

Stack Sensor with Interface For Internet Communication

- Install the Stack Sensor
- Install the Platinum Control and set it up on the Internet
- Wire the Stack Sensor, Stack Network Interface, and NPS to the Platinum control Network input,
- Set the Stack Sensor on the ICMS site,
- Set the Stack Sensor's Hi Alarm and deliveries

Installing Stack Sensor

- Drill a 1/2" hole through the stack wall for the bushing.
- Screw the sensor plate to the stack through the four screw holes. The Plate can be bent to match the stack roundness
- Push the sensor probe through the bushing into the stack.
- Run the high temperature wire through one of the knockouts of the Handybox.
- The sensor is provided with high temperature wire. This wire cannot be cut or spliced until it has been run to a location where the temperature does not exceed 120°F. Once the high temperature wire has been run to this lower temperature area, the wire can be extended up to 500' by splicing it with 18#AWG shielded cable (Belden #8760 or equivalent (#18/2)).

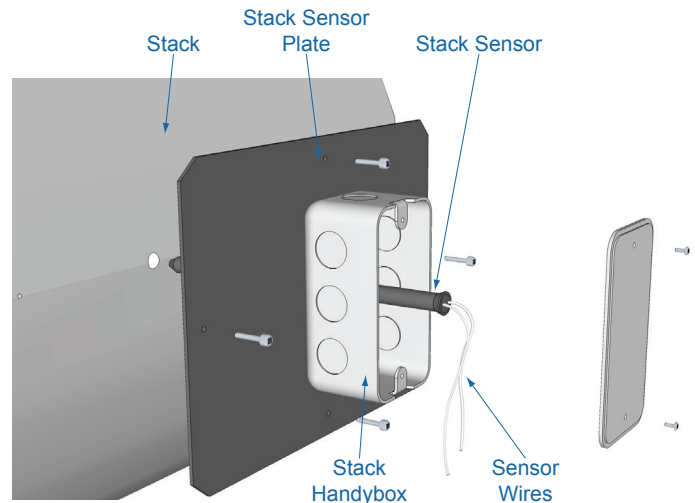

⚠ WARNING

DO NOT install the Stack Network Interface on the stack. DO NOT cut or splice the high temperature wire provided with the sensor until it has been run to an area where the temperature will not exceed 120°F.

Wiring Stack Sensor to SPC-Elite

- The Stack Sensor with the SPC-Elite is used to activate an alarm when the stack temperature increases above a critical level. The SPC-Elite alarm output is used to trigger a Vis-U-Alarm (925011-00), any visual or audible alarm, or an EMS input.

Wiring the Stack Sensor to SPC-Elite

- The sensor can be installed up to 500 Ft. away from the control by splicing the sensor wires with a Shielded 18 AWG 2-conductor cable (Belden #8760 or equivalent).
- Connect the Stack Sensor's wires to the SPC-Elite (T3+, T3-) terminals.
- Connect the sensor shield to an Earth Ground or (T3-) terminal. Do not connect the shield at the sensor.
- Do not run sensor wires in conduit with line voltage or in close proximity to line voltage wiring.

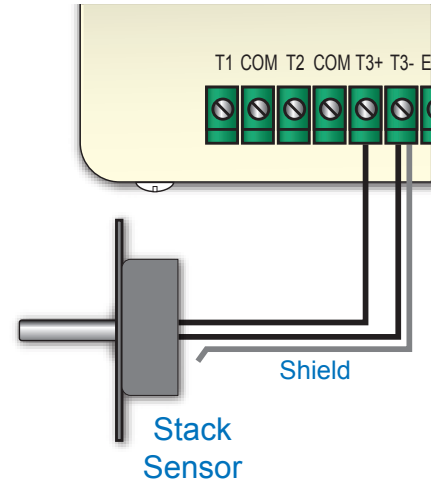

Wiring the SPC-Elite to Vis-U-Alarm or Other Alarm

- The SPC-Elite output has a SPDT relay. The Red and White wires are the N.O. relay output.
- The Vis-U-Alarm or other alarms can be wired to the Red and White wires as per the diagram on the right.
- The SPC-Elite red and white wire output does not source any power. A separate power source must be provided for the alarm.

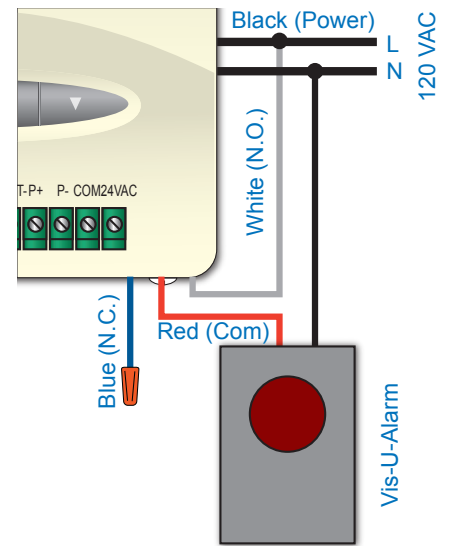

Wiring the SPC-Elite to EMS

- The SPC-Elite output acts as a SPDT relay. The Red and White wires are the perform the N.O. relay output.
- The EMS can be wired to the Red and White wires as per the diagram below to send a dry contact signal to the EMS system.
- The SPC-Elite Red and White wire output does not source any power. If the EMS requires any power, a separate power source must be provided.

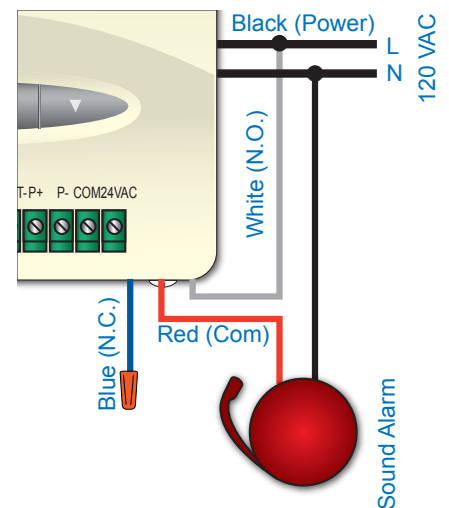
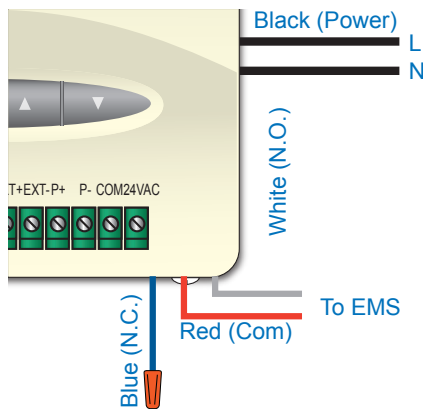

SPC-Elite Setup

The SPC-Elite must have the following Startup settings set:

- Sensor Type = Hi Temp
- Control Mode = Heat-BreakOnRise
- Then set the Set Point and Differential to the desired setting. See SPC-Elite Installation and Operation Manual for more details.

Set Point:
610°F ▸ 650°F

Differential:
10°F ▸ 20°F

HT# 059246-00B

Wiring Stack Sensor to Platinum Control

- The sensor can be installed up to 500 Ft. away from the control by splicing the sensor wires with a Shielded 18 AWG 2-conductor cable (Belden #8760 or equivalent).
- Do not cut the Stack Sensor wires as they are rated for high temperature.
- For the Stack Sensor to communicate to the Platinum control, the Stack Network Interface (904047-00) must be used. In addition, the use of the Stack Network Interface requires the use of the Network Power Supply (926670-00).
- The Stack Network Interface can be installed in any convenient location where the temperature will not exceed 120°F.
- Remove the Stack Network Interface cover to reveal its circuit board.
- Bring the Stack Sensor wires through any of the Stack Network Interface knockouts to terminals X1, X2.
- Use 16 AWG unshielded twisted pair cable for the network wiring (Belden #8471, Belden 85102, or equivalent (#16/2)).
- Bring the Network 16 AWG 2-conductor unshielded twisted pair through the Stack Network Interface knockouts to Network terminals. Connect the other end of the cable to the Platinum control's Network terminals (A7, A8).
- Screw the cover back on the handybox.
- Connect the Network Power Supply (NPS) Network terminals to the Platinum control's Network terminals (A7, A8).
- Each Stack Network Interface has a specific ID Number that is printed on a card and a white label on the circuit board. Take the ID Number Card with you and mark it with the sensor name and location for later use. This number is used on the Internet to identify the sensor.

⚠ ALERT
Fill out the Network Identification card. Otherwise, it may be difficult to identify and configure the sensors on the Internet.

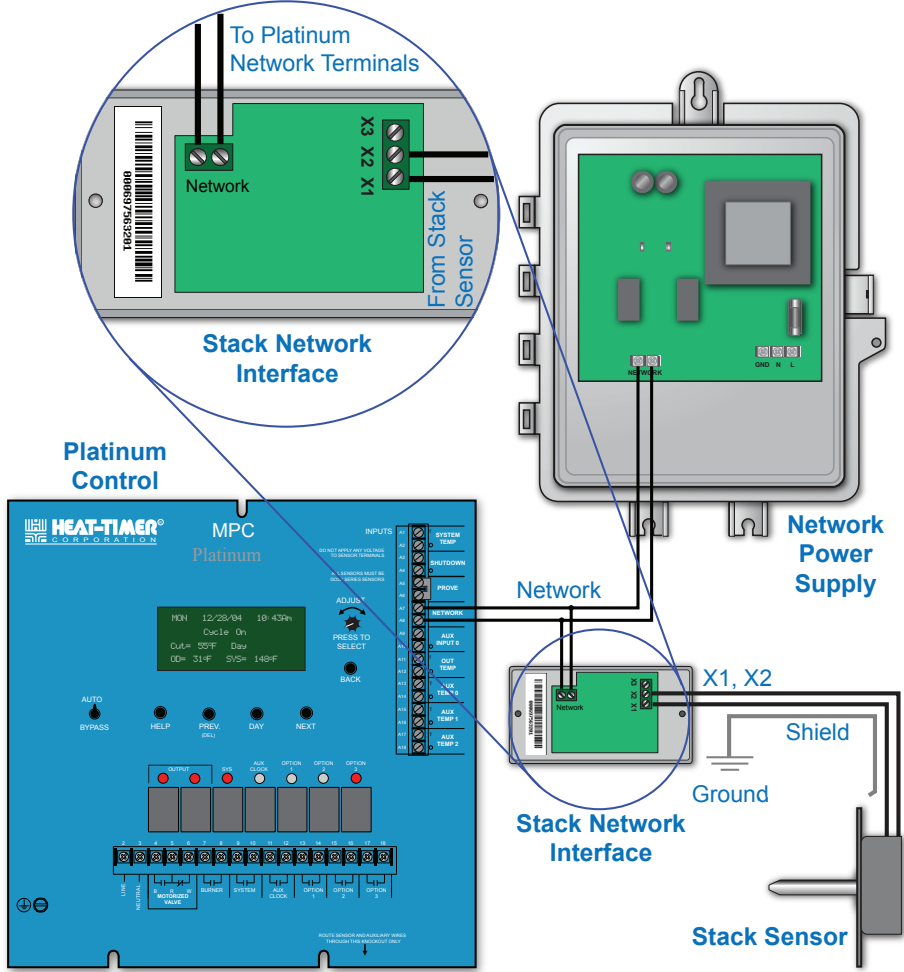

HT# 059246-00B

ICMS Website Stack Sensor Setup

- After physically installing and wiring the Stack Sensor, configure it on the ICMS site as a Network Sensor.
- Logon to <http://www.htcontrols.com> using a full rights user account number, user name, and password.
- Select the building hosting the Platinum control by clicking on the Building Icon.
- Click the “Add Device(s)” button. Then, select the “Network Sensors” option.
- A list of all un-configured sensors will be available on the left. Select the sensor with the same ID Number. Its information will be copied to the ID#. Give it a name. Then, select “Stack” as a Type. Follow that by clicking the “Configure Sensor” button. In a short time, the sensor will be available on the “Live Session”.

Control: 16 W5TH

Un-Configured Sensors
#000651933001
[no name]
Temperature
#000651933001

Sensor Info
ID #: 0006 5193 3001
Name: Stack Sensor *
Type: Stack *
Floor: BR *
Location: []

Click to configure a specified device type

 Network Sensors, MIG Sensors, Wireless Sensors, Wireless TRCVRs & Network Manager

Configure Sensor, Select Panel, Back To Building

ICMS Website Stack Sensor Alarm Setup

- From the Stack Sensor “Sensor Info” screen, select “Alarm Delivery Setup”.
- Set the “High” temperature and the “Delay” values.
- Select the “Sensor Above High Alarm” button. The button will change in color.
- Then, Click the “Add Delivery” button.
- Select the E-mail “Delivery Method” and fill the rest of the fields with the “E-mail Address”, “Subject”, and “Message” followed by clicking the “Submit” button.
- To add additional E-mail deliveries, just repeat the last step by clicking on the “Add Delivery” button.

Sensor Info | **Alarm Delivery Setup** | Back To Live Session

Control: MPC 265 W 81st
ID #: 00A2 1231 0001
Name: STACK TEMP

Alarm Settings
Delay: 300 sec(s)
Low: -40 °F High: 650 °F
Update Alarm Settings Only

Alarm Deliveries
Select an alarm type to setup deliveries

- 200 - Sensor Fault (0)
- 201 - Sensor Above High Alarm (0)
- 202 - Sensor Below Low Alarm (0)
- 5200 - Sensor Fault Ended (0)
- 5201 - Sensor Above High Alarm Ended (0)
- 5202 - Sensor Below Low Alarm Ended (0)

Configured Deliveries | Add Delivery

Delivery Info
Sensor Name: STACK TEMP
Alarm Type: 201 - Sensor Above High Alarm
Delivery Method: WEB * Show alarm to 'Monitor Mode' users
Message Text: WEB Alarm *
E-MAIL

Submit, Cancel

Stack Sensor Wiring to Platinum Control

Mechanical

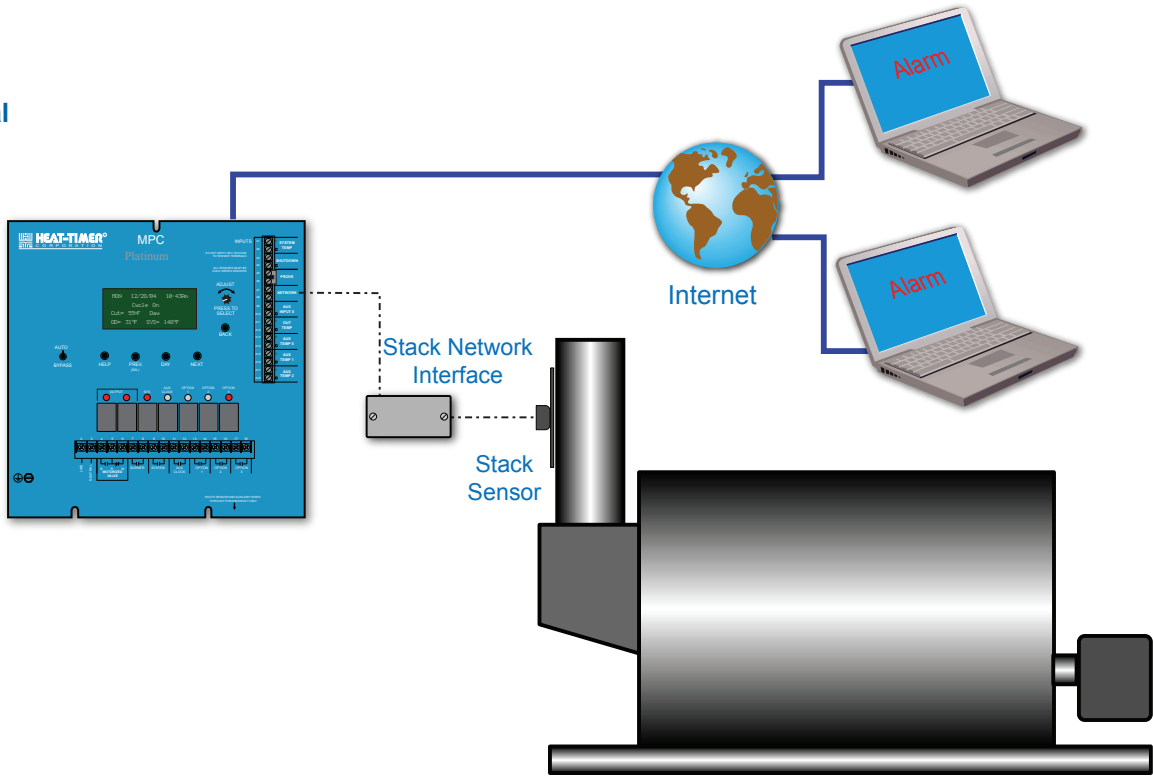

Electrical

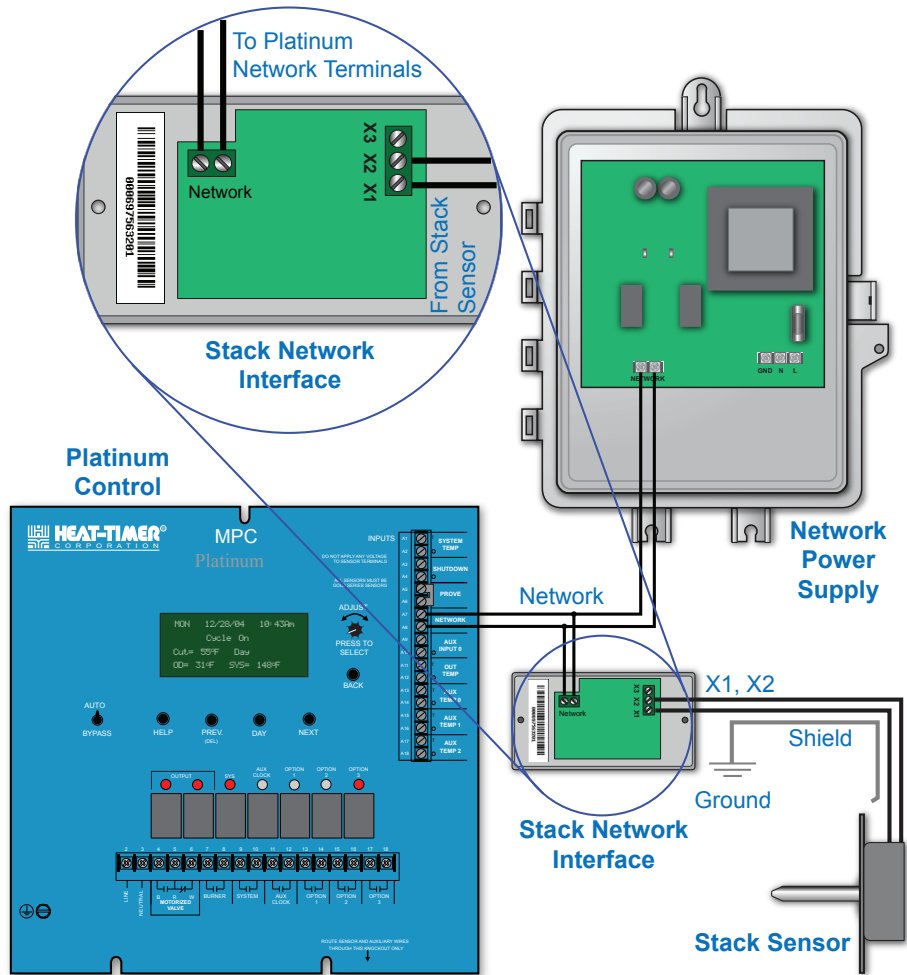

Stack Sensor Wiring to SPC-Elite

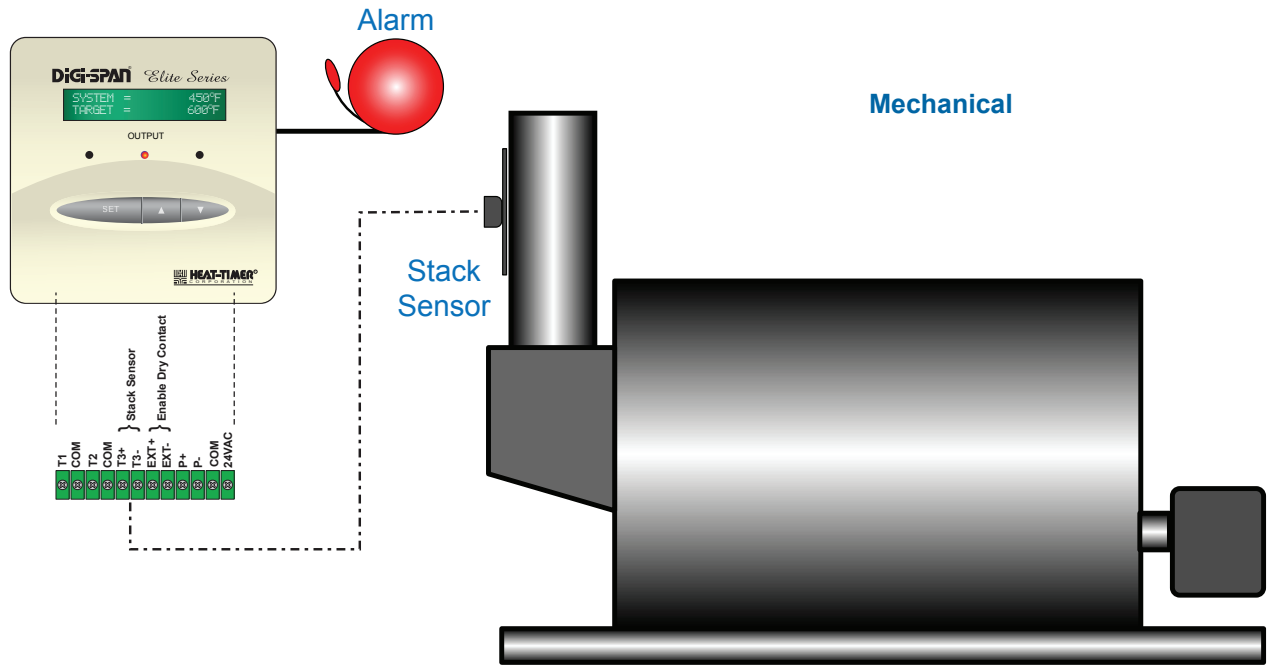

⚠ ALERT
 Heat-Timer Corp. is aware that each installation is unique. Thus, Heat-Timer Corp. is not responsible for any installation related to any diagram generated by Heat-Timer Corporation. The provided illustrations are to demonstrate Heat-Timer Corporation's control operating concept only.

Electrical

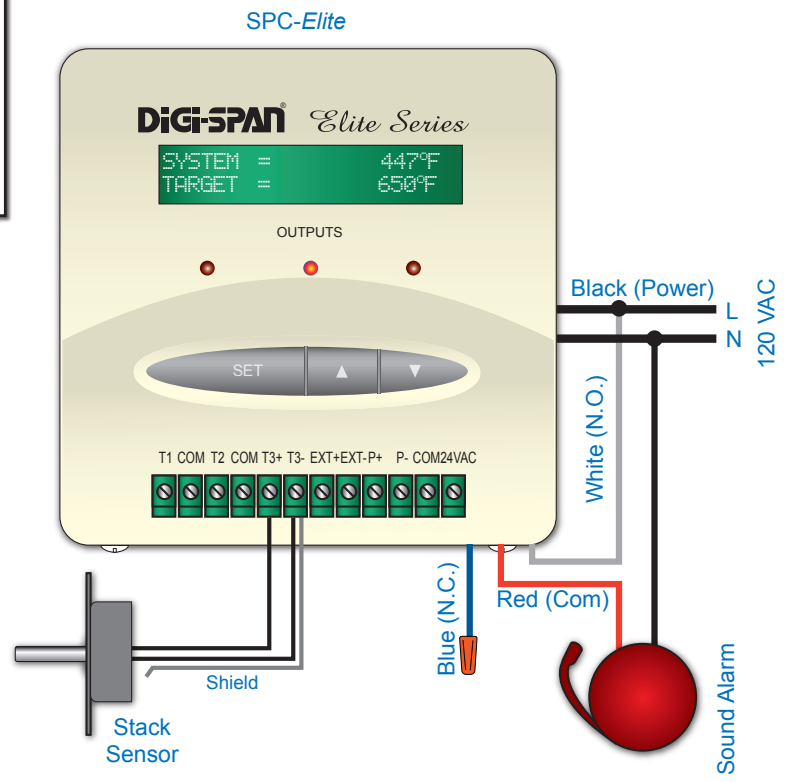

HT# 059246-00B

Troubleshooting

Stack Sensor with SPC-Elite

The SPC-Elite Stack Sensor is reading “Open” or “Short”.

- Make sure that the SPC-Elite Sensor Type is set to “**Hi Temp**” and that the sensor is wired to terminals T3+, T3-. The control will not recognize sensors connected to any other terminals.
- If the sensor was reading “Open”, connect the SPC-Elite terminals (T3+, T3-) with a jumper. The control should read “Short”. If it did not, the control is damaged. If it did, then check the sensor wiring for continuity using a continuity-meter.
- If the sensor was reading “Short”, disconnect the SPC-Elite terminals (T3+, T3-)wires. The control should read “Open”. If it did not, the control is damaged. If it did, then check the sensor wiring. Look for spliced or damaged wires.

The SPC-Elite Stack Sensor is reading incorrect temperature.

- Check the sensor Ohm reading. The reading must match the Stack Temperature Resistance Table.

Stack Sensor on the Internet

The Internet Stack Sensor is reading “Disconnected”.

- Make sure that the NPS is connected and functioning (See NPS Manual). The NPS provides 42 VDC power for up to 5 network sensors. If more network sensors are used, a second NPS must be used.

The Internet Stack Sensor is reading “Open” or “Short”.

- Make sure that the Sensor Type is set to “**Stack**” and that the sensor is wired to the Stack Network Interface terminals X1, X2. The Stack Network Interface will not recognize sensors connected to any other terminals.
- If the sensor was reading “Open”, connect the Stack Network Interface terminals X1,X2 with a jumper. The sensor should read “Short”. If it did not, the Stack Network Interface is damaged. If it did, then check the sensor wiring for continuity using a continuity-meter.
- If the sensor was reading “Short”, disconnect the Stack Network Interface terminals X1,X2 wires. The control should read “Open”. If it did not, the Stack Network Interface is damaged. If it did, then check the sensor wiring. Look for spliced or damaged wires.

The Internet Stack Sensor is reading incorrect temperature.

- Check to make sure that the Sensor Type was set to “**Stack**”.

NOTE: Changing the Sensor Type will delete all previous history.

Stack Temperature Resistance Table

DEG°F	DEG °C	Ohms
200	93.33	1358
250	121.11	1464
275	135.00	1517
300	148.89	1569
325	162.78	1622
350	176.67	1674
375	190.56	1725
400	204.44	1773
425	218.33	1824
450	232.22	1875
475	246.11	1926
500	260.00	1977
525	273.89	2027
550	287.78	2077
575	301.67	2127
600	315.56	2174
625	329.44	2222
650	343.33	2272
675	357.22	2321
700	371.11	2370
725	385.00	2419
750	398.89	2464
800	426.67	2559
850	454.44	2655
900	482.22	2749
950	510.00	2842

Stack Sensor Specifications

Sensor operating temperature range 150°F/65°C to 950°F/510°C

Stack Network Interface Specifications

Ambient temperature 20°F/-7°C to 120°F/49°C
 Connection to Platinum control connect Network terminals to Platinum A7, A8 terminals
 Power source. requires Network Power Supply (NPS)
 Stack Sensor connection. Terminals X1, X2

HT# 059246-00B



20 New Dutch Lane, Fairfield, NJ 07004
 Ph: (973) 575-4004 • Fax: (973) 575-4052
<http://www.heat-timer.com>