

HEAT-TIMER

INSTALLATION/OPERATING INSTRUCTIONS

OIL TANK MONITOR

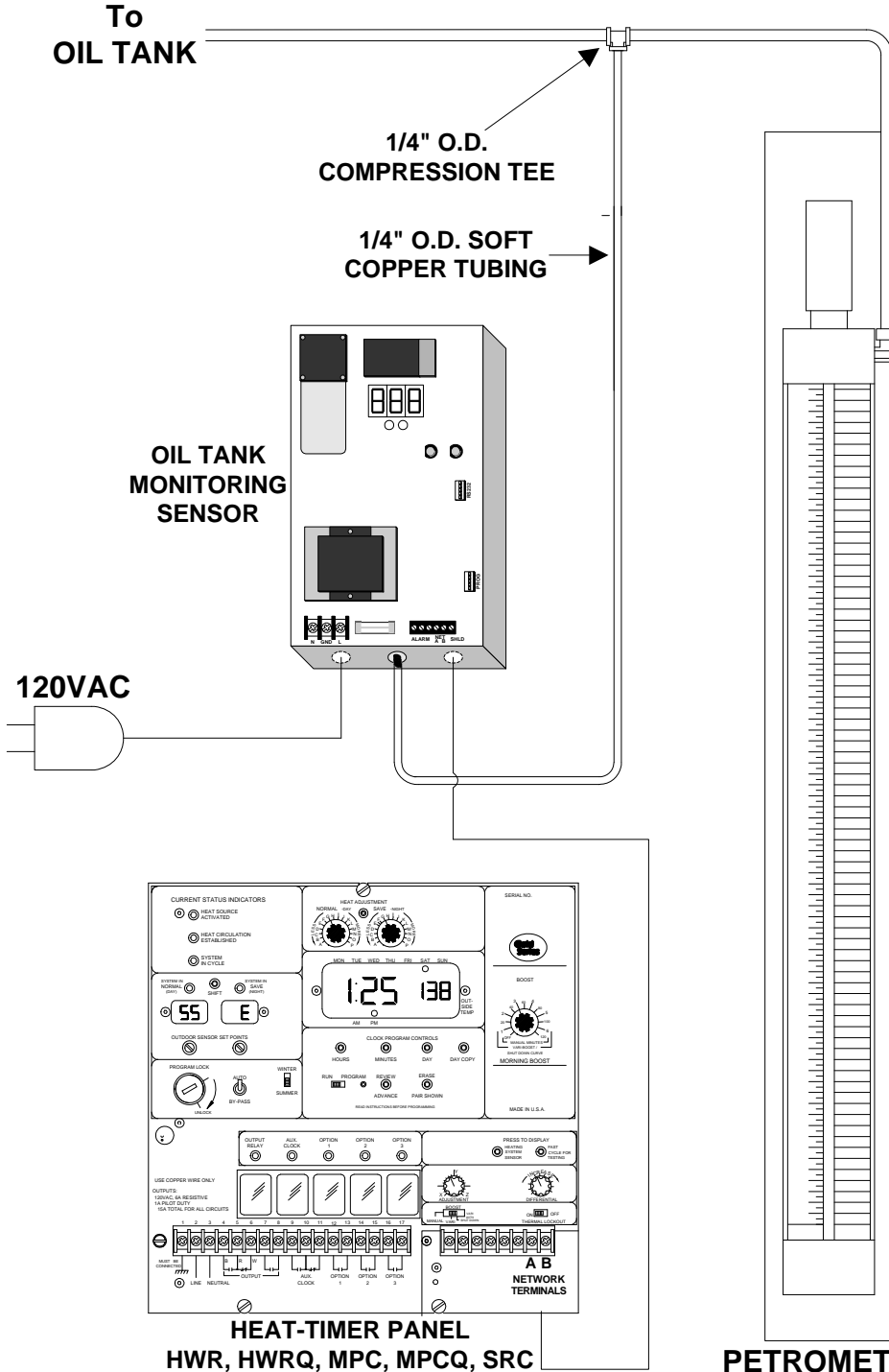

The Oil Tank Monitor displays the number of inches of oil in a tank with large 3/8" inch digits that can be clearly read from across a boiler room. The unit can activate an alarm if the oil level falls below a desired number of inches. The Oil Tank Monitor is also designed to transmit the tank level over a Heat-Timer Visual Gold Remote Communications network. The Visual Gold will allow remote users to monitor the level of the tank and dial out alarms if the tank level is outside of the desired range.

The Oil Tank Monitor has a pump for automatic pressure compensation. An internal timer energizes the pump at regular intervals to insure correct operation. The pump can also be programmed to activate immediately for testing or after maintenance.

The Oil Tank Monitor's internal programming mode allows adjustment of the Alarm value in inches and provides an offset for tube placement in the oil tank. Once programmed, these values will not be lost if power is interrupted or lost. The program values are displayed, allowing precise adjustment for each setting.

INSTALLATION

Mounting the enclosure

- The Oil Tank Monitor (OTM) can be located up to 1500' from the Heat-Timer panel: HWR, HWRQ, MPC, MPCQ, SRC.
- Locate the unit in a convenient indoor location near the existing oil tank petrometer or oil tank.
- The OTM must be located where the ambient temperature will not exceed 130°F and away from any steam or moisture.
- Use the three mounting brackets on the outside of the enclosure to secure the OTM to the selected surface.

Connecting the Probe with an Existing Petrometer

- Use 1/4" compression tees (see diagram front page).
- Break into the existing tubing from the oil tank to the petrometer and install the compression tee.
- Run 1/4" soft copper tubing from the compression tee to the brass bulkhead of the OTM, located at the bottom center of the enclosure.
- Tighten the fittings. There is no need to use Teflon tape.
- Do not over tighten. Overtightening may cause the brass bulkhead to rotate.

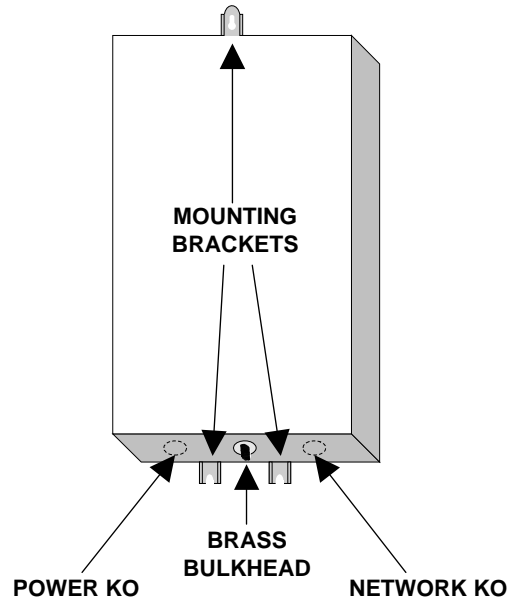

Connecting the Probe Directly into the Oil Tank

- Use 1/4" soft copper tubing.
- One end of the tubing will need to be positioned at the bottom of the tank.
- Connect the other end of the tubing to the brass bulkhead of the OTM located at the bottom center.
- Tighten the fittings. There is no need to use Teflon tape.
- Do not over tighten. Overtightening may cause the brass bulkhead to rotate.

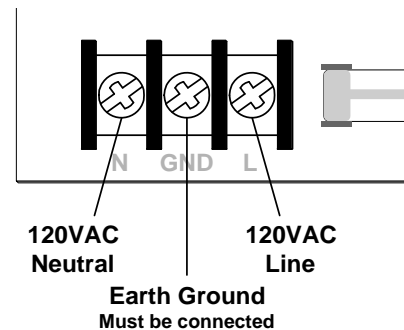

Power Wiring

- Bring the 120VAC 60Hz power wires through the Power Knockout (KO) of the enclosure. The left KO is preferred.
- Class 1 voltages must enter the enclosure through a different opening from any Class 2 voltage wiring.
- Connect the hot line to terminal marked *L*.
- Connect the neutral line to the terminal marked *N*.
- The terminal marked *GND* **MUST** be connected to earth ground.

Alarm Wiring

- The OTM can be used to activate an external alarm when the tank level falls below a selectable level.
- The *ALARM* outputs are internally connected to one Normally Open (N.O.) relay.
- The *ALARM* contacts are dry contacts only. They do not source any voltage.
- Class 1 voltages must enter the enclosure through a different opening from any Class 2 voltage wiring.
- The N.O. contact is capable of switching 1Amp resistive at 120VAC.

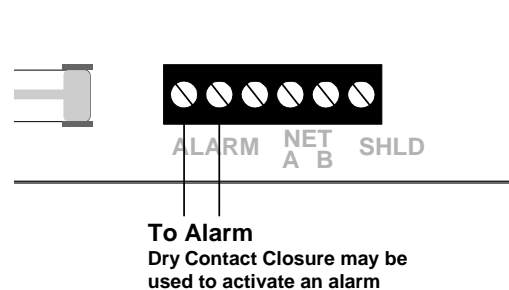

Network Wiring

- Use 2-wire **unshielded twisted pair** (see specification below).
- There is no polarity to observe. Either network wire from the OTM can be attached to Heat-Timer panel (HWR, HWRQ, MPC, MPCQ, SRC) Network terminals *A* or *B*.
- Network wiring must enter the enclosure through a different opening from any Class 1 voltage wiring.
- The wires can be run in virtually any configuration back to the Heat-Timer panel. They can be wired sensor to sensor (daisy chained). They can be wired in a star configuration, with each sensor pair brought back to the panel. Finally, there can be any combination of the two.

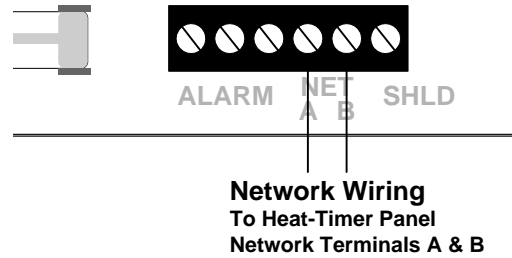

Wire	Type	Gauge	Maximum Length (ft)	Maximum Temp (°F)
Belden 8471	Unshielded Twisted Pair	16AWG	1200	140
Belden 85102	Unshielded Twisted Pair	16AWG	1500	185

OPERATION

Power Up

- On power up, the three digit digital display will first show *Htc* for approximately 5 seconds. This will be followed by the version number of the software.
- The display will then go blank and the pump will activate to clear air out of the tube for pressure compensation.
- After approximately 30 seconds, the display will show the current value of the number of inches of oil in the tank.

Digital Display

- During normal operation, the OTM three digit display will show the number of inches of oil in the tank.
- If the display flashes, this indicates the OTM has set the Alarm. This happens when the oil level in the tank is lower than the adjustable *ALr* (Alarm) level (see Programming).
- The display will go off whenever the pump is running. The pump activates periodically during normal operation. If the Power indicator light is on (see below), but the display is blank, the pump may have been running. Wait a minute and the display will return.
- Pressing the *CHANGE* button will cause the OTM to enter the programming mode.
- See the chart on the next page for programming.
- After selecting *Oil* from the programming mode, or after 30 seconds, the OTM will resume displaying the number of inches of oil in the tank.

Display shows current oil level or programming mode

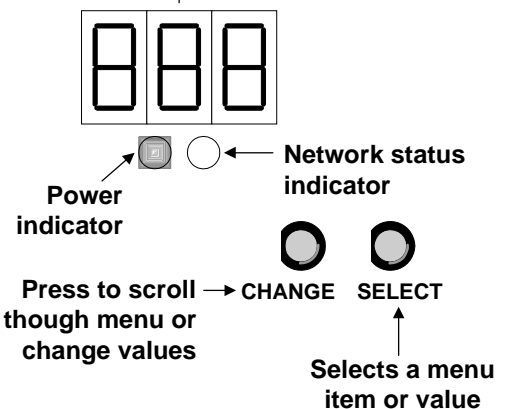

LED Indicators

- The left red LED Power indicator (see side diagram) should be on whenever there is power to the OTM.
- The right red LED Network status indicator should normally be off.
- Occasional blinking of Network status indicator is caused by intermittent communication problems with the Heat-Timer

- panel and may be caused by electrical noise on the network. Check the wiring specification on the previous page.
- If the Network status indicator is always on, contact the factory.

Programming

- The *CHANGE* and *SELECT* buttons (see pg. 3) are used in programming.
- After adjusting a setting to the desired value, the *SELECT* button must be pressed. This saves the new value to memory.
- Settings will not be lost if power is interrupted.
- The following chart shows the programmable parameters and how to adjust them:

Press <i>CHANGE</i>	Display Code	Press <i>SELECT</i> to see current value Press <i>CHANGE</i> to adjust current value When the desired value is displayed, press <i>SELECT</i> to save to memory
Once	PuP Pump	Turning the PuP to ON will activate the pump immediately after the programming mode is exited. This can be used to remove air whenever maintenance is performed on the tubing. It can also be used to test the pump. If OFF is selected, the pump will run at its periodically scheduled interval.
Twice	OFS Offset	The Offset value compensates for the fact that the copper tube does not extend down to the bottom of the oil tank. Its end is usually 5" above the bottom. The Offset can be adjusted from -15 to 15 inches.
3 Times	ALr Alarm	When the oil level falls below the Alarm value, the display will flash and the Alarm contacts will close. The Alarm can be adjusted from 0 to 100 inches.
4 Times	OIL	Selecting OIL will cause the OTM to immediately begin normal operation. If the PuP was set to ON , selecting OIL will cause the pump to run immediately. Note that if OIL is not selected, the OTM will automatically revert back to normal operation after approximately 30 seconds.

Network Configuration

- The OTM has a specific ID number. The ID number is on the back of the OTM, and is on the Network Identification card which is provided with the unit. Fill out the location of the OTM on the Network Identification card and return it to the Heat-Timer Network administrator.
- The OTM can only be used with Visual Gold versions 2.31 or higher. The CPU board on the Heat-Timer panel (HWR, HWRQ, MPC, MPCQ, SRC) must be Rev F or higher, and the software version on the Heat-Timer panel must be version 3.09 or higher.
- When configuring the OTM in Visual Gold, it must be set as a Level Type sensor.
- Visual Gold can display the inches of oil in the tank at the remote location. To display the number of gallons in the tank, it is necessary to know all of the following about the tank: shape (cylindrical or rectangular), orientation (vertical or horizontal), height, diameter, and capacity. All this information must be entered into Visual Gold correctly for Visual Gold to display the correct value.