

Installation and Operation Manual

Installation or Upgrading Platinum Control to MODBUS

MODBUS RTU (RS485)

PLATINUM CONTROL REAR VIEW

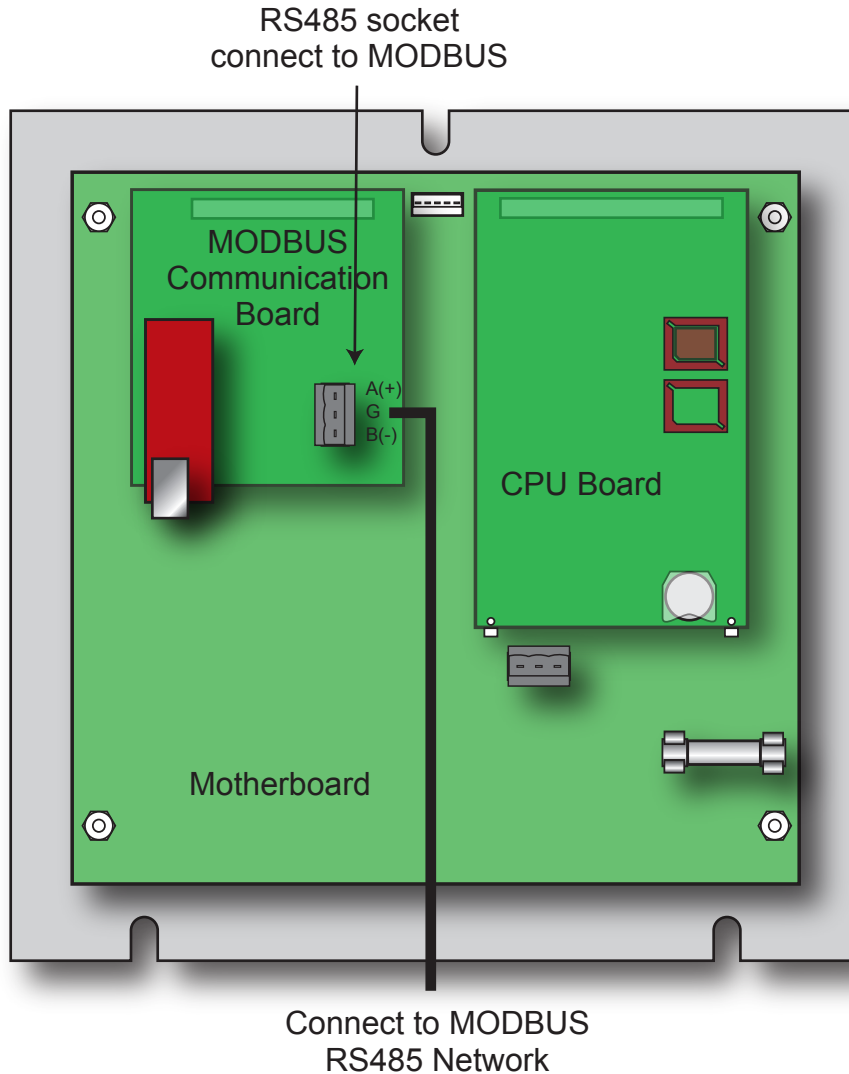

⚠ WARNING

This Heat-Timer control is strictly an operating control; it should never be used as a primary limit or safety control. All equipment must have its own certified limit and safety controls required by local codes. The installer must verify proper operation and correct any safety problems prior to the installation of this Heat-Timer control.

CONTENT

MODBUS Type	3
MODBUS RS485 Wiring	3
MODBUS RTU Communication Configuration	3
MODBUS Communication Options	3
MAC Address	3
Baud	3
Troubleshooting	3
HWR Platinum MODBUS Variable List	4
HWRQ Platinum MODBUS Variable List	6
Multi-MOD Platinum MODBUS Variable List	8
MPC Platinum MODBUS Variable List	10
MPCQ Platinum MODBUS Variable List	11
SRC Platinum MODBUS Variable List	14
Warranty	16

MODBUS TYPE

- Heat-Timer Platinum controls can be ordered with or upgraded to MODBUS communication.
- The Platinum MODBUS communication uses RTU protocol and RS485 wiring.
- When upgrading a standard Platinum control to MODBUS communication, the CPU Board on the back of the Platinum control must be replaced. In addition, the MODBUS Communication Board must be installed. See "Platinum Control Rear View" on page 1.

MODBUS RS485 WIRING

- Heat-Timer Platinum control MODBUS communication uses a RS485 connection.
- Connect the RS485 to the back of the Platinum control's MODBUS Communication Board.
- Use 18 AWG Twisted-Pair cable. The cable length must not exceed 3500 feet.
- The Ground RS485 terminal (G) MUST be connected to the BMS RS485 Ground.

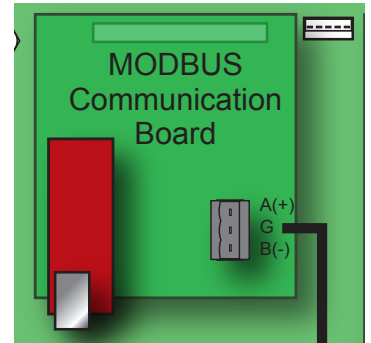

⚠ ALERT
 DO NOT USE the RS485 Connector on the Motherboard for MODBUS communication.
 Use the RS485 Connector on the MODBUS Communication Board instead.

MODBUS RTU COMMUNICATION CONFIGURATION

- If the Platinum control was purchased with or upgraded to a MODBUS communication, some of the following settings must be configured to guarantee proper communication.

```

--NETWORK SETTINGS--
MAC Address      1
# Baud           9600
  
```

MODBUS COMMUNICATION OPTIONS

SELECT: MENU/<Maintenance>/Network Settings

SELECT: MENU/<Settings>/<More Settings>/<Remote Interface>/Network Settings

**Multi-MOD Platinum
All Other Platinum Controls**

- Before connecting the Platinum control to the MODBUS network, the user must set the following parameters according to the MODBUS Network Administrator's instructions.

MAC ADDRESS

Options: From 1 to 247

Default: 1

- This is a unique ID within the MODBUS network. It must be provided by the MODBUS Network Administrator.

```

----- MAC ADDRESS -----
                1
[ ■                ]
  
```

BAUD

Options: 9600, 19200, 38400

Default: 9600

- The Baud determines the speed of communication.
- Both the Platinum control and BMS must use the same Baud rate.
- The communication is fixed to 8 Data Bits, No Parity, and 2 Stop Bits.

```

----- BAUD RATE -----
# 9600
 19200
 38400
  
```

⚠ ALERT
 MODBUS capable Platinum controls will display --NETWORK PANEL--
 on the 2nd row of the display when in screen saver mode.

TROUBLESHOOTING

If no communication is the symptom, check the following:

- Make sure that RS485 A(+) and B(-) terminals polarity is correct. Otherwise, there will be no communication.
- Both devices must have the same Baud rate. Successful communication depends on matching the Baud rate of both devices.
- Check that the RS485 G terminal is connected properly.

If intermittent communication is the symptom, check the following:

- Make sure that the communication cable is of the twisted-pair type.
- Reliable communication depends on the cable length and Baud rate used. Long cable length may require a lower Baud rate.

HWR PLATINUM MODBUS VARIABLE LIST

HWR REG / VARIABLE#	DESCRIPTION	MULT ^{†1} (if not 1)	UOM	RANGE / STATES / SPECIAL VALUES	READ ONLY
1 – 3	Model			6 Character string ^{†3}	X
4 – 13	Serial Number			20 Character string ^{†3}	X
14	Firmware Version	100			X
15	Burner Differential		°C, °F	0 - 8°C, 0 - 15°F	
16	Boost Offset		°C, °F	0 - 33°C, 0 - 60°F	
17	Boost Mode			0=Off, 1=Vari Boost, 2=Vari-Boost + ESD	
18,19	Bypass Time(4)		Minutes	0 - 2,147,483,647 ^{†4}	X
20	Burner			0=Off, 1=On	X
21	Bypass Mode			0=Auto, 1=Valve Close, 2=Valve Open / Bypass	
22	Outdoor Cutoff		°C, °F	0 - 25°C, 30 - 75°F	
23	DHW Call Mode			0=No Priority, 1= Priority	
24	Day Light Saving			0=Enable, 1=Disable	
25	Sensor Fault Mode			0=Output On, 1=Output Off	
26	Fast Cool Down			0=Minimum Water Temp, 1=Off	
27	Sensor Type			0=°F, 1=°C	
28	Minimum Water Temp		°C, °F	21 - 71°C, 70 - 170°F	
29	Outdoor Sensor		°C, °F	-40 - +122°C, -40 - +250°F (32000 =Open, 32001=Shorted) ^{†2}	X
30	Outdoor Sensor Trim		°C, °F	-3 - +3°C, -5 - +5°F	
31	Offset Temperature		°C, °F	-22 - +22°C, -40 - +40°F	
32	Output Mode			0=Burner, 1=Motorized Valve	
33	Panel Date		Days since 1/1/1981	0 - 36500	
34	Pump Run-On		Minutes	0 - 60	
35	Panel Time		Minutes since 0:00	0 - 1439, 1440=not set	
36	Pump			0=Off, 1=On	X
37	Reset Ratio			0=1:3, 1=1:2, 2=1:1.5, 3=1:1.25, 4=1:1, 5=1.25:1, 6=1.5:1, 7=2:1, 8=3:1, 9=4:1	
38 through 93	Day/Night Schedules		Minutes since 0:00	0 - 1439, 1440=empty schedule	
94	Season			0=Winter, 1=Summer	
95	Night Setback Temp		°C, °F	-44 - 0°C, -80 - 0°F	
96	Day Night Shift			0=ToDay, 1=ToNight, 2=ExtendDay, 3= Resync	
97	System Sensor		°C, °F	-40 - +122°C, -40 - +250°F (32000=Open, 32001=Shorted) ^{†2}	X
98	System Sensor Trim		°C, °F	-3 - +3°C, -5 - +5°F	
99	Calculated Target		°C, °F	0 - 116°C, 0 - 240°F	X
100	Motorized Valve			0=Inactive, 1=Closing, 2=Opening	X
101	Max Target Temp		°C, °F	32 - 116°C, 90 - 240°F	

HT# 059266-00A

HWR Platinum Notes

- ◆1 If specified, divide a read value by this to obtain the actual value – Multiply desired value by this before writing.
- ◆2 For variables that specify them, if a read value is a special value (32000 - 32005), do not divide by 'MULT'.
- ◆3 Strings are packed 2 characters per register, most significant byte first.
- ◆4 Multi-register values are stored **big endian** (first register x 65536 + second register = value).

Note: All variables are stored as 'Holding Registers'. MODBUS functions :

- 'Read Holding Registers' (function code 3),
- 'Write Single Register' (function code 6),
- and 'Write Multiple Registers' (function code 16) are supported.

Note: All variables with multiple UOM's depend upon the value of 'Input Mode' to determine which to use.

Note: Use 'Burner Differential' and 'Burner' when 'Output Mode' is set to Burner.
Use 'Valve' when 'Output Mode' is set to Motorized Valve.

Note: Use 'Boost' when 'Boost Mode' is set to Vari Boost or Vari Boost + ESD.

Note: The HWR Platinum has a schedule, which is 7-days, 4 day/night pairs per day. For example: Register 38 is the first DAY schedule of Monday; Register 39 is the first NIGHT schedule of Monday; Register 46 is the first DAY schedule of Tuesday; Register 47 is the first NIGHT schedule of Tuesday and so on.

Note: Use HWR Platinum Installation and Operation manual for supplementary information.

HWRQ PLATINUM MODBUS VARIABLE LIST

HWRQ REG / VARIABLE#	DESCRIPTION	MULT *1 (if not 1)	UOM	RANGE / STATES / SPECIAL VALUES	READ ONLY
1 – 3	Model			6 Character string *3	X
4 – 13	Serial Number			20 Character string *3	X
14	Firmware Version	100			X
15	Boost Offset		°C, °F	0 - 33°C, 0 - 60°F	
16	Boost Mode			0=Off, 1=Vari Boost, 2=Vari Boost + ESD	
17,18	Bypass Time		Minutes	0 - 2,147,483,647 *4	X
19 through 50	Boiler Status		(BTYPE=0)® (BTYPE=1)® (BTYPE=2)® (BTYPE=3)®	0=Off, 1=On 0=Off, 1=Low, 2=High 0=Off, 1=Low, 2=Med, 3=High, 0=Off, 1=Low, 2=MLow, 3=Mhigh, 4=High	X
51	Boiler Type. See "HWRQ Platinum Boiler Type Table" on page 7			0=On/Off, 1=2-Stage, 2=3-Stage, 3=4-Stage	
52	Bypass Mode			0=Auto, 1=Bypass	
53 through 84	Extension Panel Stage Communication Error			0="", 1=C/E	X
85	Control Mode			0=Reset, 1=Set Point	
86	Outdoor Cut-off		°C, °F	0 - 25°C, 30 - 75°F	
87	DHW Call Mode			0=No Priority, 1= Priority	
88	Day Light Saving			0=Enable, 1=Disable	
89	Sensor Fault Mode			0=Stages On, 1=Stages Off	
90	Fast Cool Down			0=Minimum Target Temp, 1=Off	
91	Sensor Type			0=°F Sensor, 1=°C Sensor	
92	Lead Boiler			See "HWRQ Platinum Boiler Type Table" on page 7	
93 through 124	Lockout Input			0=(inactive), 1=L/O	X
125	Logic Mode			0=PID, 1=OSS	
126	Last Stage Hold		°C, °F	0 -17°C, 0 - 30°F	
127	Min Runtime		Minutes	1-60	
128	Min Water Temp		°C, °F	21 - 77°C, 70 - 170°F	
129 through 160	Boiler Mode			0=Auto, 1=Standby, 2=Off, 3=On	
161	Total Boilers			1 – 32 / (BTYPE+1)	
162	Outdoor Sensor		°C, °F	-40 – 121°C, -40 - +250°F (32000=Open, 32001=Shorted)*2	X
163	Outdoor Sensor Trim		°C, °F	-3 - +3°C, -5 - +5°F	
164	Offset Temp		°C, °F	-22 - +22°C, -40 - +40°F	
165	Panel Date		Days since 1/1/1981	0 – 36500	
166	Pump Run-On		Minutes	0 - 60	
167	Panel Time		Minutes since 0:00	0 – 1439, 1440=not set	
168	Pump			0=Off, 1=On	X
169	Purge Delay		Minutes	0-10	
170	Reset Ratio			0=1:3, 1=1:2, 2=1:1.5, 3=1:1.25, 4=1:1, 5=1.25:1, 6=1.5:1, 7=2:1, 8=3:1, 9=4:1	
171	Reaction Time		Minutes	1 - 10	

HT# 059266-00A

HWRQ REG / VARIABLE#	DESCRIPTION	MULT ^{†1} (if not 1)	UOM	RANGE / STATES / SPECIAL VALUES	READ ONLY
172	Lead Stage Rotation Mode			0=Time, 1=Manual, 2=FOFO (No FOFO for 'Logic Mode'=OSS)	
173	Periodic Rotation Interval		Hours	1 - 999	
174 through 229	Day/Night Schedules		Minutes since 0:00	0 – 1439, 1440=not set	
230	Season			0=Winter, 1=Summer	
231	Sequence			0=Lo/Hi/Lo/Hi, 1=Lo/Lo/Hi/Hi	
232	Night Setback Temp		°C, °F	-44 - 0°C, -80 – 0°F	
233	Set point		°C, °F	21 - 116°C, 70 - 240°F,	
234	Day Night Shift			0=To-Day, 1= To-Night, 3=To-Schedule, 2=Extend-Day,	
235	Standby Delay		Minutes	1 - 60	
236	System Sensor		°C, °F	-40 – 121°C, -40 - +250°F (32000=Open, 32001=Shorted) ^{†2}	X
237	System Sensor Trim		°C, °F	-3 - +3°C, -5 - +5°F	
238	Calculated Target		°C, °F	0 - 116°C, 0 – 240°F (32003 - Off) ^{†2}	X
239	'Throttle Range' Range		°C, °F	1 – 11°C, 2 - 20°F	
240	Max Target Temp		°C, °F	32 – 116°C, 90 – 240°F	

HWRQ Platinum Boiler Type Table

Boiler Type	LEAD – Special value (Up to Total Boilers – 1)
0	0 – 31 ► 'A', 'B', 'C', ..., 'X', 'Y', 'Z', 'a', 'b', 'c', 'd', 'e', 'f'
1	0 – 15 ► 'AB', 'CD', 'EF', ..., 'WX', 'YZ', 'ab', 'cd', 'ef'
2	0 – 9 ► 'ABC', 'DEF', 'GHI', ..., 'STU', 'VWX', 'abc', 'def'
3	0 – 7 ► 'ABCD', 'EFGH', 'IJKL', 'MNOP', 'QRST', 'UVWX', 'abcd', 'efgh'

HWRQ Platinum Notes

- ♦1 If specified, divide a read value by this to obtain the actual value – Multiply desired value by this before writing.
- ♦2 For variables that specify them, if a read value is a special value (32000 - 32005), do not divide by 'MULT'.
- ♦3 Strings are packed 2 characters per register, most significant byte first.
- ♦4 Multi-register values are stored **big endian** (first register x 65536 + second register = value).

Note: All variables are stored as 'Holding Registers'. MODBUS functions :

- 'Read Holding Registers' (function code 3),
- 'Write Single Register' (function code 6),
- and 'Write Multiple Registers' (function code 16) are supported.

Note: All variables with multiple UOM's depend upon the value of 'Input Mode' to determine which to use.

Note: Use 'Burner Differential' and 'Burner' when 'Output Mode' is set to Burner.
Use 'Valve' when 'Output Mode' is set to Motorized Valve.

Note: Use 'Boost' when 'Boost Mode' is set to Vari Boost or Vari Boost + ESD.

Note: 'Boiler Status' range changes with 'Boiler Type'. For example: when 'Boiler Type' is set to 0, 'Boiler Status' range is 0 to 1; when 'Boiler Type' is set to 1, 'Boiler Status' range is 0 to 2

Note: Use 'Last Stage Hold', 'Min Runtime', 'Offset', 'Purge', 'Reset Ratio', 'Reaction Time', 'Standby Delay' when 'Logic Mode' is set to 0.

Note: Use 'Reaction Time' when 'Lead Stage Rotation Mode' is set to 0.

Note: Use 'Throttle Range' when 'Logic Mode' is set to 1.

Note: Use 'Max Target' when 'Control Mode' is set to 0.

Note: The HWRQ Platinum has a schedule, which is 7-days, 4 day/night pairs per day. For example: Register 38 is the first DAY schedule of Monday; Register 39 is the first NIGHT schedule of Monday; Register 46 is the first DAY schedule of Tuesday; Register 47 is the first NIGHT schedule of Tuesday and so on.

Note: Use HWRQ Platinum Installation and Operation manual for supplementary information.

MULTI-MOD PLATINUM MODBUS VARIABLE LIST

Multi-MOD REG / VARIABLE#	DESCRIPTION	MULT *1 (if not 1)	UOM	RANGE / STATES / SPECIAL VALUES	READ ONLY
1 – 3	Model			6 Character string *3	X
4 – 13	Serial Number			20 Character string *3	X
14	Firmware Version	100			X
(15-16) through (53-54) *4	Stage Run-Time *4 (Stages 1-20) (Two registers per stage)		Minutes	0 - 2,147,483,647 *4	X
55	Outdoor Cutoff Temp		°C, °F	-6 - 38°C (-7=OFF, 39=ON) 20 - 100°F (19=OFF, 101=ON)	
56 through 75	Ignition Level(Stages 1-20)		%	1 - 50	
76	Modulation Gain	20	none	-10 - +10 (non process), 1.0 - 10.0 (process temp), 0.25 - 20.0(process psi)	
77	Heat/Cool Mode			0=heat, 1=cool	
78	High Fire Hold		Minutes	0 - 60	
79	Input Mode			0=°F, 1=°C, 2=15psi, 3=30psi, 4=100psi, 5=200psi, 6=300psi, 7=HWR, 8=Reset °F, 9=Reset °C	X
80	Lead Stage			0 - 19 = A - T	
81	Pre-purge Delay	10	Minutes	0.0 - 10.0	
82 through 101	Lockout Input(Stages 1-20)			0=(inactive), 1=Lockout, 2=Comm Error	X
102	Last Stage Hold	10	Psi, Psi, °C, °F	0 - 3.0psi 0 - 30psi, °C, °F	
103 through 122	Manual Modulation Level(Stages 1-20)		%	0 - 100	
123	Maximum Stages		none	4 - 20	X
124	Minimum Target		°C, °F	21 - 68°C, 70 - 180°F	
125 through 144	Stage Mode(Stages 1-20)			0=Auto, 1=Standby, 2=Manual, 3=Off, 4=On	
145 through 164	Modulation Start Point(Stages 1-20)		%	0 - 99	
165 through 184	Modulation Output Trim(Stages 1-20)	10	none	-1.0 - +1.0	
185	Outdoor Sensor		°C, °F	-40 - +122°C, -40 - +250°F (32000=Open, 32001=Shorted)*2	X
186	Outdoor Sensor Trim		°C, °F	-5 - +5	
187	Offset Temp		°C, °F	-28 - +28°C, -50 - +50°F	
188	Panel Date		Days since 1/1/1981	0 – 36,500	
189	Panel Time		Minutes since 0:00	0 – 1439 (1440='not set')	

HT# 059266-00A

Multi-MOD REG / VARIABLE#	DESCRIPTION	MULT ^{♦1} (if not 1)	UOM	RANGE / STATES / SPECIAL VALUES	READ ONLY
190	Reset Ratio			0=1:4, 1=1:3, 2=1:2, 3=1:1.5, 4=1:1.25, 5=1:1, 6=1.25:1, 7=1.5:1, 8=2:1, 9=3:1, 10=4:1	
191	Lead Stage Rotation Mode			0=Manual, 1=Time, 2=Last-On	
192	Periodic Rotation Interval		Hours	1 - 999	
193	Setback	10	Psi, Psi, °C, °F	0 - 7.5psi 0 - 75psi, °C, °F	
194	Set point	10	Psi, Psi, °C, °F	0.0-15.0psi, 0.0-30.0psi 0-100psi, -40 to +122°C, -40 to +250°F	
195	System Run-on		Minutes	0 to 360	
196	Standby Delay		Minutes	1 - 60	
197 through 216	Stage Relay(Stages 1-20)			0=Off, 1=On	X
217 through 236	Modulation Level(Stages 1-20)		%	0 to 100	X
237	System Relay			0=Off, 1=On	X
238	System Sensor	10	Psi, Psi, °C, °F	0.0 to 15.0psi, 0.0 to 30.0psi, 0 - 100psi, -40 - +122°C, -40 - +250°F (32000 =Open, 32001=Shorted) ^{♦2}	X
239	Calculated Target		°C, °F	21 - 122°C, 70 - 250°F	X

Multi-MOD Platinum Notes

- ♦1 If specified, divide a read value by this to obtain the actual value – Multiply desired value by this before writing.
- ♦2 For variables that specify them, if a read value is a special value (32000 - 32005), do not divide by 'MULT'.
- ♦3 Strings are packed 2 characters per register, most significant byte first.
- ♦4 Multi-register values are stored **big endian** (first register x 65536 + second register = value).

Note: All variables are stored as 'Holding Registers'. MODBUS functions

- 'Read Holding Registers' (function code 3),
- 'Write Single Register' (function code 6),
- and 'Write Multiple Registers' (function code 16) are supported.

Note: All variables with multiple UOM's depend upon the value of 'Input Mode' to determine which to use. Objects with only °F/°C UOM's default to °F when 'Input Mode' is not temperature.

Note: 'Offset Temp', 'Reset Ratio' and 'Calculated Target' are not used unless 'Input Mode' is set to 'Reset °F' or 'Reset °C'.

Note: When writing to the 'Manual Modulation Level' of a stage, the 'Stage Mode' of that stage will change to 'Manual'.

Note: Use the Multi-Mod Platinum Installation and Operation manual for supplementary information.

MPC PLATINUM MODBUS VARIABLE LIST

MPC REG / VARIABLE#	DESCRIPTION	MULT ^{♦1} (if not 1)	UOM	RANGE / STATES / SPECIAL VALUES	READ ONLY
1 – 3	Model			6 Character string ^{♦3}	X
4 – 13	Serial Number			20 Character string ^{♦3}	X
14	Firmware Version	100			X
15	Vari-Boost Adjustment	10	none	0.1 – 6.4	
16	Boost Mode			0=Disabled, 1=Manual, 2=Vari, 3=Vari+ESD	
17	Manual Boost Time		Minutes	0 – 120	
18,19	Bypass Time		Minutes	0 – 2,147,483,647 ^{♦4}	X
20	Bypass Mode			0=AUTO, 1=ON	
21	Cycle Length		Minutes	10 – 240	
22	Day Heat Adjustment			0 – 15 = A – P	
23	Outdoor Day Cutoff		°C, °F	-6 – 38°C, 20 – 100°F	
24	Day Light Saving			0=Enable, 1=Disable	
25	Sensor Fault Mode			0=OutputOn, 1=OutputOff	
26	System Differential		°C, °F	2 – 42°C, 3 – 75°F	
27	Sensor Mode			0=°F, 1=°C	
28	Night Heat Adjustment			0 – 15 = A – P	
29	Outdoor Night Cutoff		°C, °F	-6 – 38°C, 20 – 100°F	
30	Outdoor Sensor		°C, °F	-40 – 122°C, -40 – +250°F (32000=Open, 32001=Shorted) ^{♦2}	X
31	Outdoor Sensor Trim		°C, °F	-3 – +3°C, -5 – +5°F	
32	Operation Mode			0=Burner/valve, 1=District Steam	
33	Output Relay			0=Off, 1=On	X
34	Panel Date		Days since 1/1/1981	0 – 36500	
35	Panel Time		Minutes since 0:00	0 – 1439, 1440=not set	
36 through 91	Day/Night Schedules		Minutes since 0:00	0 – 1439, 1440=not set	
92	Season			0=Winter, 1=Summer	
93	Day/Night Shift			0=To-Day, 1=To-Night, 2=Extend-Day, 3=To-Schedule	
94	System Run-on		Minutes	0 – 60	
95	System Sensor		°C, °F	-40 – 122°C, -40 – +250°F (32000=Open, 32001=Shorted) ^{♦2}	X
96	System Relay			0=Off, 1=On	X
97	System Sensor Trim		°C, °F	-3 – +3°C, -5 – +5°F	
98	Thermal Lockout Enable			0=OFF, 1=ON	
99	District Steam Delay		Minutes	0 – 30	
100	System Setpoint		°C, °F	21 – 122°C, 70 – 250°F	

MPC Platinum Notes

- ♦1 If specified, divide a read value by this to obtain the actual value – Multiply desired value by this before writing.
- ♦2 For variables that specify them, if a read value is a special value (32000 - 32005), do not divide by 'MULT'.
- ♦3 Strings are packed 2 characters per register, most significant byte first.
- ♦4 Multi-register values are stored **big endian** (first register x 65536 + second register = value).

HT# 059266-00A

Note: All variables are stored as 'Holding Registers'. MODBUS functions :

- 'Read Holding Registers' (function code 3),
- 'Write Single Register' (function code 6),
- and 'Write Multiple Registers' (function code 16) are supported.

Note: All variables with multiple UOM's depend upon the value of 'Input Mode' to determine which to use.

Note: Use 'District Steam Delay' when 'Operating Mode' is set to District Steam. Use 'System Setpoint', 'System Differential' and 'Thermal Lockout Enable' when 'Operation Mode' is set to Burner/valve.

Note: Use 'Vari-Boost Adjustment' when 'Boost Mode' is set to Vari-Day or Vari+ESD. Use 'Manual Boost Time' when 'Vari-Boost Adjustment' is set to Manual Boost.

Note: The MPC Platinum has a schedule, which is 7-days, 4 day/night pairs per day. For example: Register 38 is the first DAY schedule of Monday; Register 39 is the first NIGHT schedule of Monday; Register 46 is the first DAY schedule of Tuesday; Register 47 is the first NIGHT schedule of Tuesday and so on.

Note: Use MPC Platinum Installation and Operation manual for supplementary information.

MPCQ PLATINUM MODBUS VARIABLE LIST

MPCQ REG / VARIABLE#	DESCRIPTION	MULT *1 (if not 1)	UOM	RANGE / STATES / SPECIAL VALUES	READ ONLY
1 – 3	Model			6 Character string *3	X
4 – 13	Serial Number			20 Character string *3	X
14	Firmware Version	100			X
15	Vari-Boost Adjustment	10		0.1 – 6.4	
16	Boost Mode			0=Disabled, 1=Manual, 2=Vari, 3=Vari+ESD	
17	Manual Boost Time		Minutes	0 – 120	
18,19	Bypass Time		Minutes	0 – 2,147,483,647 *4	X
20 through 51	Boiler Status		(BTYP=0)® (BTYP=1)® (BTYP=2)® (BTYP=3)®	0=Off, 1=On0=Off, 1=Low, 2=High, 0=Off, 1=Low, 2=Med, 3=High, 0=Off, 1=Low, 2=MLow, 3=Mhigh, 4=High	X
52	Boiler Type See "MPCQ Platinum Boiler Type Table" on page 12			0=On/Off, 1=2-Stage2=3-Stage, 3=4-Stage	
53	Bypass Mode			0=AUTO, 1=ON	
54	Cycle Length		Minutes	10 – 240	
55 through 86	Extension Panel Stage Communication Error			0="", 1=C/E	X
87	Day Heat Adjustment			0 – 15 = A – P	
88	Outdoor Day Cutoff		°C, °F	-6 - 38°C, 20 - 100°F	
89	Day Light Saving			0=Enable, 1=Disable	
90	Sensor Fault Mode			0=OutputOn,1=OutputOff	
91	Sensor Mode			0=°F, 1=°C	
92	Lead Boiler			See "MPCQ Platinum Boiler Type Table" on page 12	
93 through 124	Lockout Input			0=(inactive), 1=L/O	X
125	Logic Mode			0-PID, 1-OSS	
126	Last Stage Hold	10	psi	0.0 – 5.0	
127	Min Runtime		Minutes	1 – 60	
128 through 159	Boiler Mode			0=Auto, 1=Standby, 2=Off, 3=On	
160	Total Boilers			1 – 32/(BTYP+1)	
161	Night Heat Adjustment			0 – 15 = A – P	

HT# 059266-00A

MPCQ REG / VARIABLE#	DESCRIPTION	MULT ^{†1} (if not 1)	UOM	RANGE / STATES / SPECIAL VALUES	READ ONLY
162	Outdoor Night Cutoff		°C, °F	-6 – 38°C, 20 – 100°F	
163	Outdoor Sensor		°C, °F	-40 – 122°C, -40 – +250°F (32000=Open, 32001=Shorted) ^{†2}	X
164	Outdoor Sensor Trim		°C, °F	-3 – +3°C, -5 – +5°F	
165	Operation Mode			0=Cycle, 1=Set Point	
166	Panel Date		Days since 1/1/1981	0 – 36500	
167	Pressure Sensor Trim	10	psi	-3.0 – +3.0	
168	Panel Time		Minutes since 0:00	0 – 1439, 1440=not set	
169	Purge Delay	2	Minutes	0 – 10	
170	Reaction Time		Minutes	1 – 10	
171	Lead Stage Rotation Mode			0=Time	
172	Periodic Rotation Interval		Hours	1 – 999	
173 through 228	Day/Night Schedules		Minutes since 0:00	0 – 1439, 1440=not set	
229	Season			0=Winter, 1=Summer	
230	Sequence			0=Lo/Hi/Lo/Hi1=Lo/Lo/Hi/Hi	
231	Night Setback Temp	10	psi	-10.0 – 0.0	
232	Set Point	10	psi	0.0 – 30.0	
233	Day/Night Shift			0=To-Day, 1=To-Night, 2=Extend-Day,	
234	Standby Delay		Minutes	1 – 60	
235	System Pressure Sensor	10	psi	-5.0 – +35.0 (32000=Open,32001=Shorted) ^{†2}	X
236	System Run-on		Minutes	0 – 60	
237	System Relay			0=Off, 1=On	X
238	Throttle Range	2	psi	0.5 – 5.0	
239	Heat Establish Pressure	10	psi	0.5 – 5.0	

MPCQ Platinum Boiler Type Table

Boiler Type	LEAD – Special value (Up to Total Boilers – 1)
0	0 – 31 ► 'A', 'B', 'C', ..., 'X', 'Y', 'Z', 'a', 'b', 'c', 'd', 'e', 'f'
1	0 – 15 ► 'AB', 'CD', 'EF', ..., 'WX', 'YZ', 'ab', 'cd', 'ef'
2	0 – 9 ► 'ABC', 'DEF', 'GHI', ..., 'STU', 'VWX', 'abc', 'def'
3	0 – 7 ► 'ABCD', 'EFGH', 'IJKL', 'MNOP', 'QRST', 'UVWX', 'abcd', 'efgh'

MPCQ Platinum Notes

- ◆1 If specified, divide a read value by this to obtain the actual value – Multiply desired value by this before writing.
- ◆2 For variables that specify them, if a read value is a special value (32000 - 32005), do not divide by 'MULT'.
- ◆3 Strings are packed 2 characters per register, most significant byte first.
- ◆4 Multi-register values are stored **big endian** (first register x 65536 + second register = value).

Note: All variables are stored as 'Holding Registers'. MODBUS functions :

- 'Read Holding Registers' (function code 3),
- 'Write Single Register' (function code 6),
- and 'Write Multiple Registers' (function code 16) are supported.

Note: All variables with multiple UOM's depend upon the value of 'Input Mode' to determine which to use.

Note: Use 'Burner Differential' and 'Burner' when 'Output Mode' is set to Burner.
Use 'Valve' when 'Output Mode' is set to Motorized Valve.

- Note:** Use 'Vari-Boost Adjustment' when 'Boost Mode' is set to Vari-Day or Vari+ESD. Use 'Manual Boost Time' when 'Vari-Boost Adjustment' is set to Manual Boost.
- Note:** 'Boiler Status' range changes with 'Boiler Type'. For example: when 'Boiler Type' is set to 0, 'Boiler Status' range is 0 to 1; when 'Boiler Type' is set to 1, 'Boiler Status' range is 0 to 2
- Note:** Use 'Day Heat Adjustment', 'Fast Cycle', 'Night Heat Adjustment', and 'Heat Establish Pressure' if 'Operation Mode' is set to 0.
- Note:** Use 'Setback' if 'Operation Mode' is set to 1.
- Note:** Use 'Last Stage Hold', 'Min Runtime', 'Purge', 'Reaction Time', 'Standby Delay' when 'Logic Mode' is set to 0.
- Note:** Use 'Reaction Time' when 'Lead Stage Rotation Mode' is set to 0.
- Note:** Use 'Throttle Range' when 'Logic Mode' is set to 1.
- Note:** Use 'Max Target' when 'Control Mode' is set to 0.
- Note:** The MPCQ Platinum has a schedule, which is 7-days, 4 day/night pairs per day. For example: Register 38 is the first DAY schedule of Monday; Register 39 is the first NIGHT schedule of Monday; Register 46 is the first DAY schedule of Tuesday; Register 47 is the first NIGHT schedule of Tuesday and so on.
- Note:** Use MPCQ Platinum Installation and Operation manual for supplementary information.

SRC PLATINUM MODBUS VARIABLE LIST

SRC REG / VARIABLE#	DESCRIPTION	MULT *1 (if not 1)	UOM	RANGE / STATES / SPECIAL VALUES	READ ONLY
1 – 3	Model			6 Character string *3	X
4 – 13	Serial Number			20 Character string *3	X
14	Firmware Version	100			X
15	Vari-Boost Adjustment	10		0.1 – 6.4	
16	Boost Mode			0=BoostOff, 1=ManualBoost, 2=VariDay, 3=VariDayNight	
17	Manual Boost Time		Minutes	0 – 120	
18,19	Bypass Time		Minutes	0 – 2,147,483,647 *4	X
20	Burner Status			0=Off, 1=On	X
21	Bypass Mode			0=Auto, 1=Manual, 2=Bypass	
22	Cycle Length		Minutes	10 – 240	
23	Valve % at Cutoff		%	0 – 100	
24	Day Heat Adjustment			0 – 15 = A – P	
25	Outdoor Day Cutoff		°C, °F	-6 – 38°C, 20 – 100°F	
26	Day Light Saving			0=Enable, 1=Disable	
27	Sensor Fault Mode			0=OutputOn, 1=OutputOff	
28	Valve % at Freezing		%	0 - 100	
29	Sensor Mode			0=°F, 1=°C	X
30	Motor Time		Seconds	120 – 600	
31	Manual Valve Target		%	0 – 100	
32	Night Heat Adjustment			0 – 15 = A – P	
33	Outdoor Night Cutoff		°C, °F	-6 – 38°C, 20 – 100°F	
34	Outdoor Sensor		°C, °F	-40 – 122°C, -40 – +250°F (32000=Open, 32001=Shorted)*2	X
35	Outdoor Sensor Trim		°C, °F	-3 – +3°C, -5 – +5°F	
36	Valve Off %		%	0 – 100	
37	Operation Mode			0=Burner/valve, 1=District Steam	
38	Pause Time		Seconds	0 – 60	
39	Panel Date		Days since 1/1/1981	0 – 36500	
40	Panel Time		Minutes since 0:00	0 – 1439, 1440=not set	
41	Pulse Close Enable			0=No, 1=Yes	
42	Vacuum Pump Relay			0=Off, 1=On	
43 – 98	Day/Night Schedules		Minutes since 0:00	0 – 1439, 1440=not set	
99	Season			0=Winter, 1=Summer	
100	Day/Night Shift			0=To-Day, 1=To-Night, 2=Extend-Day, 3=To-Schedule	
101	System Sensor		°C, °F	-40 – 122°C, -40 – +250°F (32000=Open, 32001=Shorted) *2	X

HT# 059266-00A

SRC REG / VARIABLE#	DESCRIPTION	MULT ^{♦1} (if not 1)	UOM	RANGE / STATES / SPECIAL VALUES	READ ONLY
102	System Sensor Trim		°C, °F	-3 – +3°C, -5 – +5°F	
103	Valve Position		%	0 – 100	X
104	Valve Close Overdrive		Seconds	0 – 90	
105	Valve Close Trim		%	0 – 5	
106	Valve Mode			0=Positioning Sensor, 1=Time-Based	
107	Valve Open Trim		%	0 – 5	
108	Valve Trim		%	0 – 20	
109	District Steam Delay		Minutes	0 – 30	
110	System Setpoint		°C, °F	21 – 122°C, 70 – 250°F	

SRC Platinum Notes

- ♦1 If specified, divide a read value by this to obtain the actual value – Multiply desired value by this before writing.
- ♦2 For variables that specify them, if a read value is a special value (32000 - 32005), do not divide by 'MULT'.
- ♦3 Strings are packed 2 characters per register, most significant byte first.
- ♦4 Multi-register values are stored **big endian** (first register x 65536 + second register = value).

Note: All variables are stored as 'Holding Registers'. MODBUS functions :

- 'Read Holding Registers' (function code 3),
- 'Write Single Register' (function code 6),
- and 'Write Multiple Registers' (function code 16) are supported.

Note: All variables with multiple UOM's depend upon the value of 'Input Mode' to determine which to use.

Note: Use 'District Steam Delay' when 'Operating Mode' is set to District Steam. Use 'System Setpoint', 'System Differential' and 'Thermal Lockout Enable' when 'Operation Mode' is set to Burner/valve.

Note: Use 'Vari-Boost Adjustment' when 'Boost Mode' is set to Vari-Day or Vari+ESD. Use 'Manual Boost Time' when 'Vari-Boost Adjustment' is set to Manual Boost.

Note: The SRC Platinum has a schedule, which is 7-days, 4 day/night pairs per day. For example: Register 38 is the first DAY schedule of Monday; Register 39 is the first NIGHT schedule of Monday; Register 46 is the first DAY schedule of Tuesday; Register 47 is the first NIGHT schedule of Tuesday and so on.

Note: Use SRC Platinum Installation and Operation manual for supplementary information.

WARRANTY

WARRANTIES AND LIMITATIONS OF LIABILITY AND DAMAGE: Heat-Timer Corporation warrants that it will replace, or at its option, repair any Heat-Timer Corporation manufactured product or part thereof which is found to be defective in material workmanship within one year from the date of installation only if the warranty registration has been properly filled out and returned within 30 days of the date of installation. Damages to the product or part thereof due to misuse, abuse, improper installation by others or caused by power failure, power surges, fire, flood or lightning are not covered by this warranty. Any service, repairs, modifications or alterations to the product not expressly authorized by Heat-Timer Corporation will invalidate the warranty. Batteries are not included in this warranty. This warranty applies only to the original user and is not assignable or transferable. Heat-Timer Corporation shall not be responsible for any maladjustments of any control installed by Heat-Timer Corporation. It is the users responsibility to adjust the settings of the control to provide the proper amount of heat or cooling required in the premises and for proper operation of the heating or cooling system. Heat-Timer Corporation shall not be required to make any changes to any building systems, including but not limited to the heating system, boilers or electrical power system, that is required for proper operation of any controls or other equipment installed by Heat-Timer Corporation or any contractor. Third Party products and services are not covered by this Heat-Timer Corporation warranty and Heat-Timer Corporation makes no representations or warranties on behalf of such third parties. Any warranty on such products or services is from the supplier, manufacturer, or licensor of the product or service. See separate Terms and Conditions of Internet Control Management System (“ICMS”) services, including warranties and limitations of liability and damages, for ICMS services.

THE FOREGOING IS IN LIEU OF ALL OTHER WARRANTIES, EXPRESS OR IMPLIED AND HEAT-TIMER CORPORATION SPECIFICALLY DISCLAIMS ANY AND ALL WARRANTIES OF MERCHANTABILITY FOR A PARTICULAR PURPOSE. UNDER NO CIRCUMSTANCES SHALL HEAT-TIMER CORPORATION, ITS AUTHORIZED REPRESENTATIVES, AFFILIATED OR SUBSIDIARY COMPANIES BE LIABLE FOR SPECIAL, CONSEQUENTIAL OR INCIDENTAL DAMAGES, EXCEPT AS SPECIFICALLY STATED IN THESE TERMS AND CONDITIONS OF SALE. THE SOLE REMEDY WITH RESPECT TO ANY PRODUCT OR PART SOLD OR INSTALLED BY HEAT-TIMER CORPORATION SHALL BE LIMITED TO THE RIGHT TO REPLACEMENT OR REPAIR F.O.B. FAIRFIELD, NJ. HEAT-TIMER CORPORATION SHALL NOT BE LIABLE OR RESPONSIBLE FOR LOSS OR DAMAGE OF ANY KIND RESULTING FROM DELAY OR INABILITY TO DELIVER FOR ANY REASON, INCLUDING BUT NOT LIMITED TO FIRE, FLOOD, LIGHTNING, POWER FAILURE OR SURGES, UNAVAILABILITY OF PARTS, STRIKES OR LABOR DISPUTES, ACCIDENTS AND ACTS OF CIVIL OR MILITARY AUTHORITIES.

03122010