

Installation and Operation Manual For Boiler-Feed Chemical Monitoring Applications

Conductivity Network Sensor

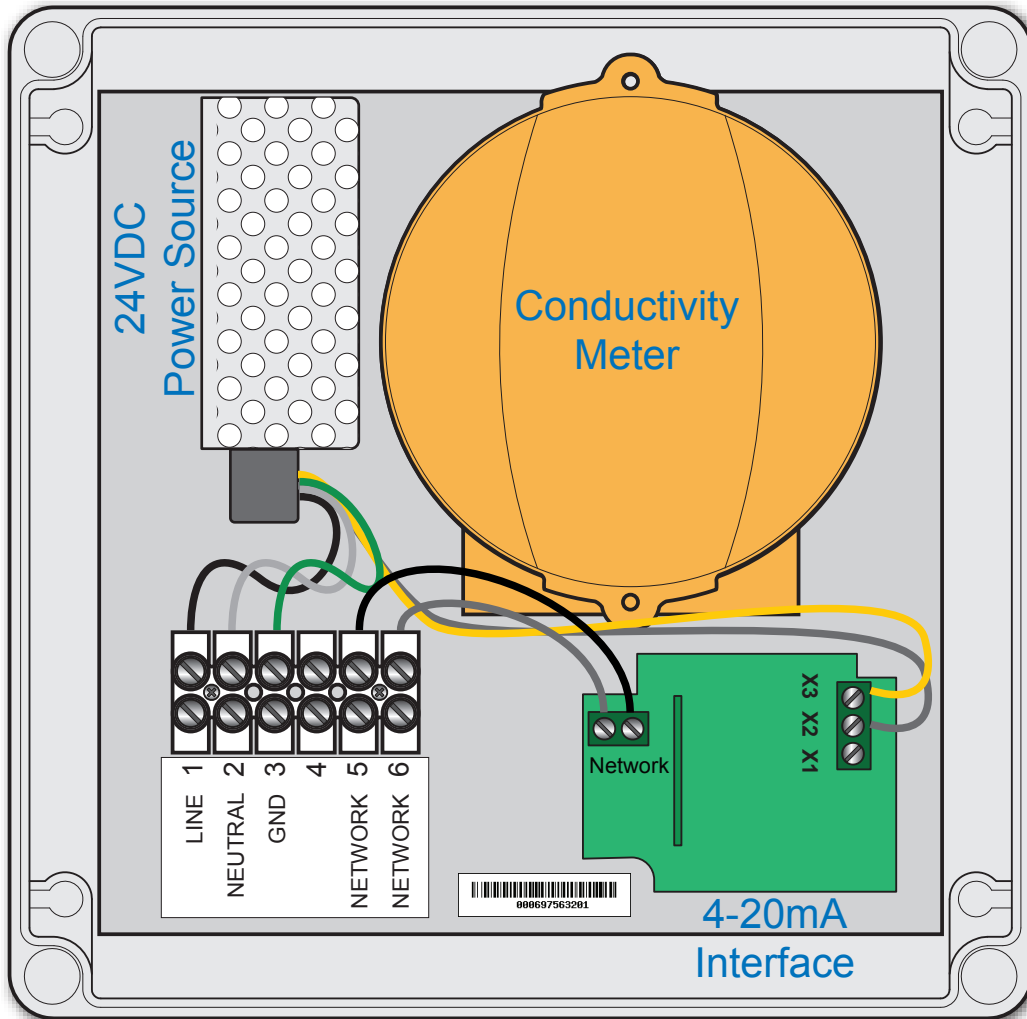

⚠ WARNING

This Heat-Timer sensor is strictly for monitoring purpose; it should never be used as a primary limit or safety control. All equipment must have its own certified limit and safety controls required by local codes. The installer must verify proper operation and correct any safety problems prior to the installation of this Heat-Timer sensor.

Overview

Due to the nature of most steam boilers, their water must be chemically treated to increase their efficiency and protect the boiler and the steam system from the adverse effects of mineral deposits. The Heat-Timer Conductivity Network Sensor provides an easy way to measure the electric conductivity of the water which can be converted to the Total Dissolved Solids (TDS) in the boiler water. Thus, help to maintain proper chemical levels. See “Converting Between $\mu\text{S}/\text{cm}$ and TDS (PPM)” on page 3.

During the operation of steam boilers, impurities from the boiler feed (oils, fats, high alkalinity, suspended solids, and dissolved solids) that do not boil off easily are left to concentrate in the boiler water. The dissolved and non-dissolved solids in addition to other contaminants tend to have the highest concentration close to the water surface. As the contaminants concentrate in the boiler water, the boiler’s steam producing capability is reduced. That is due to the steam bubbles not bursting and instead produce foam. As more contaminants are added through the feed system, there comes a point at which the majority of the steam producing surface becomes filled with foam. Foam reduces the boiler’s capability to produce steam. The steam produced will be wet and contains contaminants which are then carried over to valves, heat-exchangers, traps, and other parts of the steam system where they deposit. That is the reason Heat-Timer recommends installing the Conductivity Network Sensor in the blowdown line or right below the skim line to provide the most accurate TDS reading.

Even though there are many causes of steam boiler water foaming (oils, fats, high alkalinity, suspended solids, and dissolved solids), the TDS is the main indicator. The term Total Dissolved Solids (TDS) represents the amount of contaminants that are dissolved in the water. TDS is measured in many ways. The most common measurement is Parts-per-Million (PPM) which represents the ratio of the number of solid ions dissolved in one million parts of water. TDS is also measured by electric conductivity which uses microsiemens ($\mu\text{S}/\text{cm}$) as the unit of measure. Since conductivity varies drastically with changes in temperature, the Heat-Timer Conductivity Network Sensor provides temperature-compensated conductivity reading.

Steam boiler manufacturers instruct users to maintain their boiler water TDS levels between 1000 PPM (1500 $\mu\text{S}/\text{cm}$) and 2700 PPM (4000 $\mu\text{S}/\text{cm}$). Running the boiler at higher values for long periods will result in scale buildup on the heat-transfer surfaces reducing the overall boiler efficiency. Scale consist of Calcium Carbonate which is a great insulator, thus its surface accumulation reduces the heat transfer between the combustion surfaces and the boiler water. I.e., running a boiler with water TDS of 3500 PPM for 250 hours forms a 1/64” scale layer. This 1/64” of scale increases fuel usage by 8%. Moreover, excessive scaling can cause hot spots and premature tube failure. A scaled boiler may require acid cleaning or sometimes tube replacement. To manage the TDS range within the manufacturer recommendations, use chemicals designed for the type of boiler used and perform boiler blowdown at the chemical company’s recommended intervals.

Two of the Heat-Timer Conductivity Network Sensor advantages are its monitoring and alarming capabilities. First, since it is connected to an Internet-ready Heat-Timer Platinum control, its historical readings can be saved , graphed, and E-mailed as a report through the Heat-Timer ICMS website (<http://www.htcontrols.com>). That provides a great way to keep track of the boiler water health throughout its life.

Second, the ICMS can be set to send an alarm as an E-mail, a cell phone text message, or both when the sensor is out of an adjustable range for an adjustable time period. This feature helps alert the responsible party to the need for boiler water chemical adjustment. The alarm incorporates the sensor value, thus making it easy to determine the amount of chemicals required and possibly the change in blowdown frequency.

Converting Between $\mu\text{S}/\text{cm}$ and TDS (PPM)

The TDS (Total Dissolved Solids) can be measured in Parts-per-Million (PPM). Conductivity relation to TDS varies by the water chemical composition. Conductivity value is measured in microsiemens per centimeter ($\mu\text{S}/\text{cm}$). To convert the conductivity ($\mu\text{S}/\text{cm}$) reading to the TDS (PPM) reading, the ($\mu\text{S}/\text{cm}$) must be multiplied by a Dissolved Solids Chemical Composition Factor. This factor can be acquired through the city's water department. The factor ranges between 0.55 to 0.80. A common 0.67 factor is used as an approximation if the factor for a location is not known. The following table converts the conductivity ($\mu\text{S}/\text{cm}$) value to TDS (PPM) based on several Dissolved Solids Chemical Composition Factors including the default one (0.67).

Temperature Compensated Conductivity ($\mu\text{S}/\text{cm}$)	Dissolved Solids Chemical Composition Factor					
	0.55	0.6	0.67	0.7	0.75	0.8
	TDS measured in (PPM)					
100	55	60	67	70	75	80
300	165	180	201	210	225	240
500	275	300	335	350	375	400
700	385	420	469	490	525	560
900	495	540	603	630	675	720
1100	605	660	737	770	825	880
1300	715	780	871	910	975	1040
1500	825	900	1005	1050	1125	1200
1600	880	960	1072	1120	1200	1280
1700	935	1020	1139	1190	1275	1360
1800	990	1080	1206	1260	1350	1440
1900	1045	1140	1273	1330	1425	1520
2000	1100	1200	1340	1400	1500	1600
2100	1155	1260	1407	1470	1575	1680
2200	1210	1320	1474	1540	1650	1760
2300	1265	1380	1541	1610	1725	1840
2400	1320	1440	1608	1680	1800	1920
2500	1375	1500	1675	1750	1875	2000
2600	1430	1560	1742	1820	1950	2080
2700	1485	1620	1809	1890	2025	2160
2800	1540	1680	1876	1960	2100	2240
2900	1595	1740	1943	2030	2175	2320
3000	1650	1800	2010	2100	2250	2400
3100	1705	1860	2077	2170	2325	2480
3200	1760	1920	2144	2240	2400	2560
3300	1815	1980	2211	2310	2475	2640
3400	1870	2040	2278	2380	2550	2720
3500	1925	2100	2345	2450	2625	2800
3600	1980	2160	2412	2520	2700	2880
3700	2035	2220	2479	2590	2775	2960
3800	2090	2280	2546	2660	2850	3040
3900	2145	2340	2613	2730	2925	3120
4000	2200	2400	2680	2800	3000	3200
4200	2310	2520	2814	2940	3150	3360

Recommended Boiler Water Conductivity

Temperature Compensated Conductivity ($\mu\text{S}/\text{cm}$)	Dissolved Solids Chemical Composition Factor					
	0.55	0.6	0.67	0.7	0.75	0.8
	TDS measured in (PPM)					
4400	2420	2640	2948	3080	3300	3520
4600	2530	2760	3082	3220	3450	3680
4800	2640	2880	3216	3360	3600	3840
5000	2750	3000	3350	3500	3750	4000
5200	2860	3120	3484	3640	3900	4160
5400	2970	3240	3618	3780	4050	4320
5600	3080	3360	3752	3920	4200	4480
5800	3190	3480	3886	4060	4350	4640
6000	3300	3600	4020	4200	4500	4800
6200	3410	3720	4154	4340	4650	4960
6400	3520	3840	4288	4480	4800	5120
6600	3630	3960	4422	4620	4950	5280
6800	3740	4080	4556	4760	5100	5440
7000	3850	4200	4690	4900	5250	5600
7200	3960	4320	4824	5040	5400	5760
7400	4070	4440	4958	5180	5550	5920
7600	4180	4560	5092	5320	5700	6080
7800	4290	4680	5226	5460	5850	6240
8000	4400	4800	5360	5600	6000	6400
8200	4510	4920	5494	5740	6150	6560
8400	4620	5040	5628	5880	6300	6720
8600	4730	5160	5762	6020	6450	6880
8800	4840	5280	5896	6160	6600	7040
9000	4950	5400	6030	6300	6750	7200
9200	5060	5520	6164	6440	6900	7360
9400	5170	5640	6298	6580	7050	7520
9600	5280	5760	6432	6720	7200	7680
9800	5390	5880	6566	6860	7350	7840
10000	5500	6000	6700	7000	7500	8000
10200	5610	6120	6834	7140	7650	8160
10400	5720	6240	6968	7280	7800	8320
10600	5830	6360	7102	7420	7950	8480
10800	5940	6480	7236	7560	8100	8640
11000	6050	6600	7370	7700	8250	8800

Item List

The complete sensor assembly comes with the following:

Conductivity Network Sensor Assembly (HT# 904350-00)

- Conductivity Sensor
- Conductivity Control with 4-20mA Network Interface

The Conductivity Control can be connected to an Internet-ready Platinum control. The sensor and its alarms must be configured on the web using the ICMS (<http://www.htcontrols.com>). Alarms will be in the form of viewable web alarm, E-mail, or text message to a cellular phone.

Required Add-ons

- Network Power Supply (HT# 926670-00)

Installation Steps

Conductivity Network Sensor For Internet Communication

- Install the Conductivity Sensor in the steam boiler (Less than 15 Psi Operating pressure).
- Wire the Conductivity Sensor to the Conductivity Control,
- Wire the Conductivity Control to the Network terminals on the Platinum control,
- Configure the sensor on the ICMS site,
- Set alarm set point, delay and deliveries

⚠ WARNING

The Conductivity Sensor is a sensitive device. It **MUST NOT** be installed in an environment that is known to exceed the sensor's Maximum Temperature or Operating Pressure ratings. See "Conductivity Sensor Specification" on page 8.

Installing Conductivity Sensor

- The sensor can only be used in low pressure steam boiler (Less than 15 Psi Operating pressure). It must not be used on systems that are over 15 PSI.
- Choose a blowdown valve tapping location on the boiler that will be in the blowdown or right below the skimline. Right below the water skimline has the highest level of contaminants. Thus, will give the most accurate conductivity reading.
- Plan ahead. Turn off the boiler at least 4 hours prior to installing the sensor to guarantee working on a cold boiler.
- Drain the boiler water to a level just below the blowdown tapping used.
- If the sensor is installed horizontally below the skimline, its probe openings must be vertical for better accuracy and to allow for vertical flow.

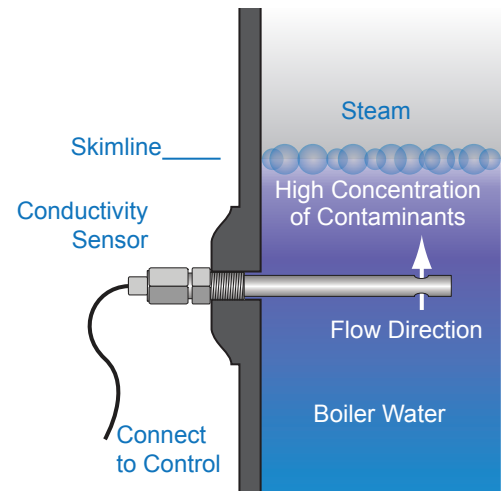

⚠ WARNING

Install the Conductivity Sensor in the boiler when the boiler is COLD and water level has been drained below the tapping used. DO NOT INSTALL IN A HOT BOILER.

Wiring Sensor to the Conductivity Control

- The Conductivity Sensor is equipped with 65 feet of cable. It can be extended up to 100 Ft. using a 3-conductor shielded or 4-conductor cable (Belden 9770 or equivalent).
- Connect all 4 sensor wires to the Conductivity Control as indicated in the drawing (from left to right: Red, Black, White, Shield). To protect the equipment, disconnect the Conductivity Control power before wiring the sensor.

⚠ WARNING

The Conductivity Control is calibrated to the Conductivity Sensor used. DO NOT Push the Calibration button or change the Dip Switch setting on the Conductivity Control. As this may cause calibration loss.

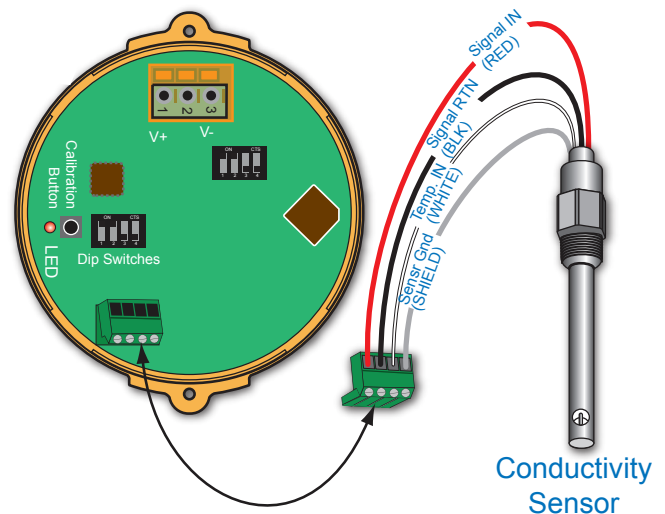

HT# 059288-00 A

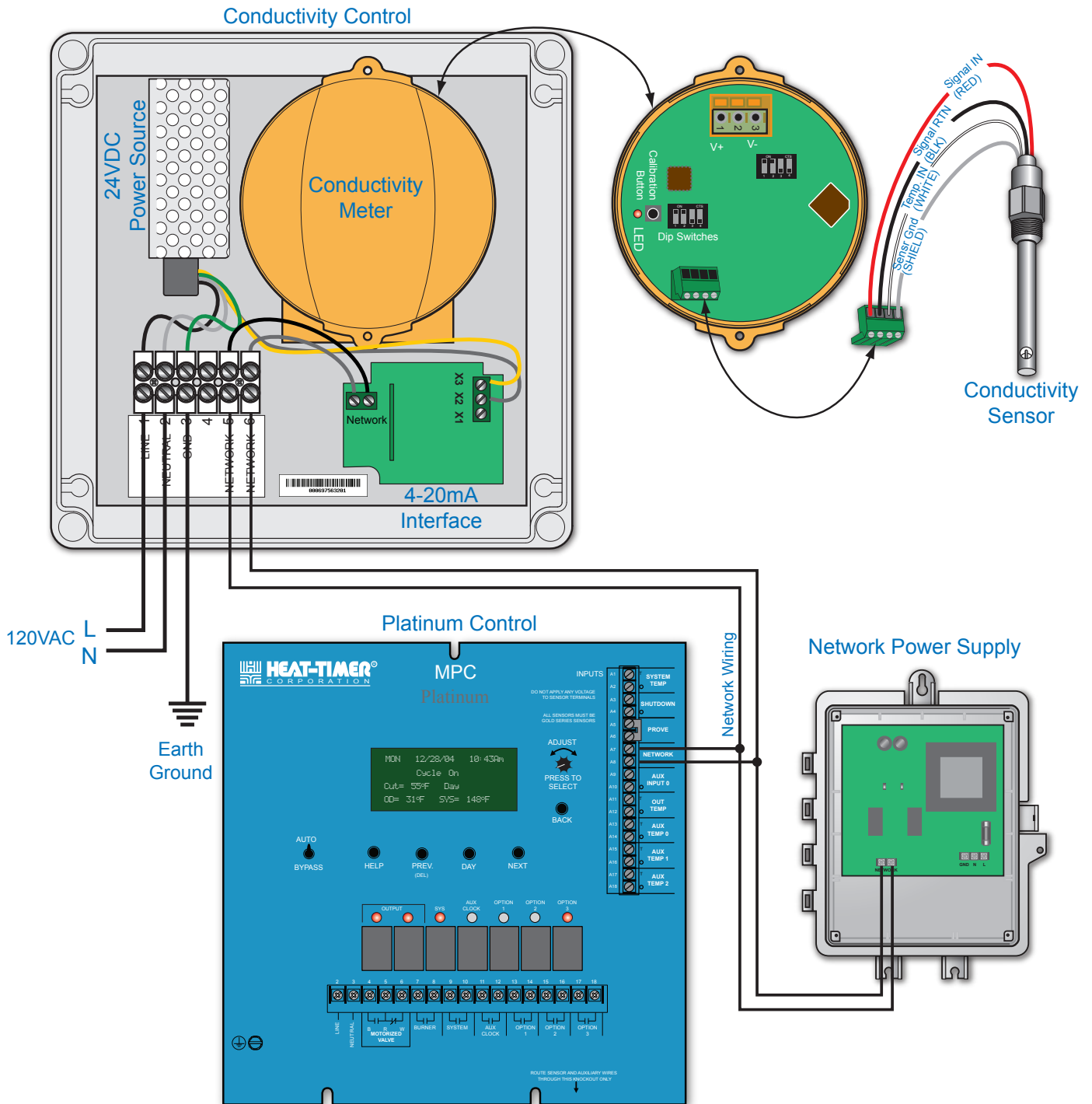

Wiring Conductivity Control to Platinum

- Connecting the Conductivity Control Network Terminals (5 and 6) to the Platinum Network Input terminals (A7 and A8).
- Connect the NPS Network terminals to the Platinum Network terminals. No polarity is observed. The NPS can power up to 5 Network sensors.
- Record the 12 digit Conductivity Control Device ID. This number is used to identify the Conductivity Sensor on the ICMS.

Wiring Conductivity Control to Power

- Connect the Conductivity Control's Terminal (1) to the 120 VAC Line.
- Connect the Conductivity Control's Terminal (2) to the 120 VAC Neutral.
- Connect the Conductivity Control's Terminal (3) to an Earth Ground.

Dip Switch Settings

- The Conductivity Control is designed to operate a variety of Conductivity Sensors. And since conductivity values are temperature sensitive, the control dip switch setting is set to have the conductivity value temperature-compensated.
- The graphed Dip Switch settings represent the standard 1.0 Cell (10-10,000 $\mu\text{S}/\text{cm}$) Conductivity Sensor with temperature compensation. Make sure to have the dip switches checked prior to powering the unit. (DIP 1 = ON, DIP 2 = ON, DIP 3 = OFF, DIP 4 = OFF).
- If the Dip Switch settings were changed after the powering of the unit, it may take up to 20 seconds to see the change take effect.

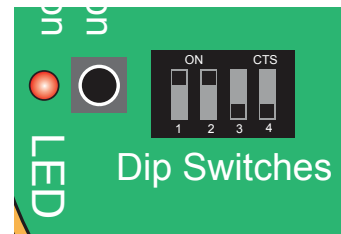

ICMS Site Conductivity Sensor Setup

After physically installing and wiring the Conductivity Sensor, configure the transducer on the ICMS site as a Network Sensor.

- Logon to <http://www.htcontrols.com> using a full rights user using the account number, user name and password.
- Select the building hosting the Platinum control by clicking on the Building Icon.
- Click the “Add Device(s)” button. Then, select the “Network Sensors” option.
- A list of all un-configured sensors will be available on the left. Select the sensor with the same Device ID. Its information will be copied to the ID#. Give it a name.
- Then, select Conductivity 10-10,000 as the Type. Follow that by clicking the “Configure Sensor” button.

Control: HEAT-TIMER MPC Plat

Un-Configured Sensors

#000697563201



[no name]
Pressure

Click to configure a specified device type



Network
Sensors



MIG
Sensors



Wireless
Sensors



Wireless TRCVRs &
Network Manager

Sensor Info

ID #:

Name: *

Type: *

Floor:

Location:

Pressure - 0 -200

Pressure - 0 -30

Pressure - 0 -300

Compound

Conductivity - 0 -100

Conductivity - 0 -1000

Conductivity - 10 -10000

Humidity

Vacuum

Configure
Sensor

Select
Panel

Back To
Building

ICMS Site Conductivity Sensor Alarm Setup

⚠️ ALERT

To send an alarm as a text message to a cellular phone, use the 10 digit cellular number followed by “@” and the cellular carrier MMS or SMS (Text) address. Contact the cellular carrier for details on their address format.

After configuring the Conductivity Sensor on the ICMS site, configure the alarm High Set Point and delay. Then, configure the deliveries to E-mail, cellular phone text message, and web deliveries.

- Logon to <http://www.htcontrols.com> as a full rights user.
- Select the Sensor List in the “Live Session”. Then, select the Conductivity Sensor.
- Click the “Alarm Delivery Setup” button.
- Set the “High” to 3 inches above the normal Clean-Filter Vacuum Reading as a starting point. If the Clean-Filter Vacuum Reading was 4 inches, then the “High” should be set to 7 inches.

- Set the “Delay” to 300 seconds to reduce false alarms.
- Click the “201 - Sensor Above High Alarm” button. It shall be shaded with Red.
- Then, click the “Add Delivery” button on the right. This will open a new page to enter the Alarm Delivery Setup.
- In the “Delivery Method” Select either “Web” or “E-mail”. The “E-mail” option is used for E-mail or cellular text message (contact your cellular phone carrier for text message address format”.

Conductivity Sensor Cleaning

- The Conductivity Control is pre-calibrated to the 1.0 Cell Conductivity Sensor. It should maintain its calibration throughout its life and power cycles.
- However, if the reading was incorrect (did not change significantly with added chemicals), contaminants deposit on the Conductivity Sensor’s probe or entrapped air bubbles may be the culprit. In this case the probe may require cleaning.
- Plan ahead. Turn off the boiler at least 4 hours prior to removing the sensor to guarantee working on a cold boiler.
- Drain the boiler water to a level just below the blowdown tapping used.
- To clean the Conductivity Sensor, use a mild detergent and a cotton swab to remove any coatings on electrodes or probe metal surface.
- If after the cleaning the sensor reading was not accurate, contact Heat-Timer Technical Support. In this case, both the Conductivity Control and Conductivity Sensor may need to be re-calibrated at the factory.

Troubleshooting

The Conductivity Sensor is reading disconnected

- This means that the 4-20mA Network Interface is not communicating to the Platinum Control. Check the Interface wiring to the Platinum Network terminals.
- Also, check that the Network Power Supply (NPS) is connected to the Platinum Network terminals and that it is providing 42 VDC to the Network terminals. If not, it may be damaged. Also, make sure that the installation has a maximum of 5 network sensors per a single NPS. If more than 5 network sensors are used, an additional NPS may be required.

The Conductivity Sensor is reading Short or Open

- Check the wiring between the Conductivity Control and the 4-20mA Network Interface. See “Wiring Conductivity Control to Platinum” on page 5..

The Conductivity Sensor reading is incorrect

- If the incorrect reading was persistent, the Conductivity Sensor may need to be cleaned from deposits. See “Conductivity Sensor Cleaning” on page 7..

Conductivity Control Specification

Operating Temperature	14°F/-10°C to 185°F/85°C
Operating Humidity	0 to 95%, non-condensing
Control Power	120 VAC (24V Power Supply included and wired)
Communication to 4-20mA Transmitter	(2-wire) 4-20mA
Dip Switches	1 to 4 to match Conductivity Sensor and Temperature Compensation
Dimension	7-1/8" x 7-1/8" x 4-1/4"
Weight	2 Pound

Conductivity Sensor Specification

Power	Through Conductivity controller
Cell	1.0 cell (10 to 10,000 µS Temperature Compensated)
Accuracy	±2% of full range.
Maximum Temperature	248°F/120°C
Fitting	1/2" NPT Stainless Steel
Operating Pressure	Less than 15 Psi
Maximum Pressure	100 Psi
Dimension	6" x 1/2" - 1/2 NPT
Weight	1 Pound

Warranty

WARRANTIES AND LIMITATIONS OF LIABILITY AND DAMAGE: Heat-Timer Corporation warrants that it will replace, or at its option, repair any Heat-Timer Corporation manufactured product or part thereof which is found to be defective in material workmanship within one year from the date of installation only if the warranty registration has been properly filled out and returned within 30 days of the date of installation. Damages to the product or part thereof due to misuse, abuse, improper installation by others or caused by power failure, power surges, fire, flood or lightning are not covered by this warranty. Any service, repairs, modifications or alterations to the product not expressly authorized by Heat-Timer Corporation will invalidate the warranty. Batteries are not included in this warranty. This warranty applies only to the original user and is not assignable or transferable. Heat-Timer Corporation shall not be responsible for any maladjustments of any control installed by Heat-Timer Corporation. It is the users responsibility to adjust the settings of the control to provide the proper amount of heat or cooling required in the premises and for proper operation of the heating or cooling system. Heat-Timer Corporation shall not be required to make any changes to any building systems, including but not limited to the heating system, boilers or electrical power system, that is required for proper operation of any controls or other equipment installed by Heat-Timer Corporation or any contractor. Third Party products and services are not covered by this Heat-Timer Corporation warranty and Heat-Timer Corporation makes no representations or warranties on behalf of such third parties. Any warranty on such products or services is from the supplier, manufacturer, or licensor of the product or service. See separate Terms and Conditions of Internet Control Management System ("ICMS") services, including warranties and limitations of liability and damages, for ICMS services.

THE FOREGOING IS IN LIEU OF ALL OTHER WARRANTIES, EXPRESS OR IMPLIED AND HEAT-TIMER CORPORATION SPECIFICALLY DISCLAIMS ANY AND ALL WARRANTIES OF MERCHANTABILITY FOR A PARTICULAR PURPOSE. UNDER NO CIRCUMSTANCES SHALL HEAT-TIMER CORPORATION, ITS AUTHORIZED REPRESENTATIVES, AFFILIATED OR SUBSIDIARY COMPANIES BE LIABLE FOR SPECIAL, CONSEQUENTIAL OR INCIDENTAL DAMAGES, EXCEPT AS SPECIFICALLY STATED IN THESE TERMS AND CONDITIONS OF SALE. THE SOLE REMEDY WITH RESPECT TO ANY PRODUCT OR PART SOLD OR INSTALLED BY HEAT-TIMER CORPORATION SHALL BE LIMITED TO THE RIGHT TO REPLACEMENT OR REPAIR F.O.B. FAIRFIELD, NJ. HEAT-TIMER CORPORATION SHALL NOT BE LIABLE OR RESPONSIBLE FOR LOSS OR DAMAGE OF ANY KIND RESULTING FROM DELAY OR INABILITY TO DELIVER FOR ANY REASON, INCLUDING BUT NOT LIMITED TO FIRE, FLOOD, LIGHTNING, POWER FAILURE OR SURGES, UNAVAILABILITY OF PARTS, STRIKES OR LABOR DISPUTES, ACCIDENTS AND ACTS OF CIVIL OR MILITARY AUTHORITIES.

03122010

HT# 059288-00A



20 New Dutch Lane, Fairfield, NJ 07004
Ph: (973) 575-4004 • Fax: (973) 575-4052
<http://www.heat-timer.com>